

Setra Relative Humidity Sensor Line



Applications

- HVAC/R Control
- Indoor Air Quality (IAQ)
- Laboratories
- Antiquities Preservation

Features

- Key part of comprehensive HVAC solution package (i.e. humidity, pressure and current)
- Active Temperature with Jumper-Selectable Tspan Ranges of 40°C, 50°C and 60°C
- Three levels of RH accuracy: 2%, 3%, and 5%
- Excellent reliability via unique, proven, and established ASIC technology
- Robust, proven capacitive sensor technology
- Easy field-serviceability
- Low cost of ownership
- High aesthetic/ low profile wall-mount enclosure
- Quick-mount, 2-screw install w/ plug-in terminal wiring
- 1 year warranty on sensor; 3 year warranty on rest of unit.
- CE and RoHS Compliant

**Now Features
Active
Temperature
Sensing**

When it comes to a product to rely on - choose the SRH.

When it comes to a company to trust - choose Setra.

setra
ISO-9001 Certified

800-257-3872

Visit Setra Online:
<http://www.setra.com>

Setra's Humidity Sensor (SRH) family consists of a wall mount, duct mount, and outside air unit. This product line is designed to complement Setra's pressure and current products while expanding the solution opportunities for the HVAC/building automation market and other relative humidity monitoring applications. All models feature removable sensor tips, NIST traceability, and a durable capacitive sensor capable of full-scale 0 to 100% RH measurement.

The SRH product line offers accurate humidity with active or passive temperature sensing available in $\pm 2\%$, $\pm 3\%$, or $\pm 5\%$ RH accuracy. Humidity transmitters configured with active temperature option feature jumper-selectable Tspan ranges of 40°C, 50°C, and 60°C.

This product suite utilizes field-replaceable sensor tips that allow the end user to replace the sensors on-site. This essentially eliminates time consuming and costly factory calibration, while reducing downtime during service intervals. As an example, the duct mount probe is easily accessed by taking off the front cover, pulling out the probe, and replacing the sensor tip. This further contributes to a more user-friendly, lower cost product line that is focused on customer needs and ease of use.

Setra's humidity sensors are the ultimate product for any HVAC installation and, combined with our pressure and current products, allow us to support a one-stop, single source for any customer. The SRH line is a natural progression that grew out of our high quality line of pressure transducers that also use the same unique ASIC coupled with a highly reliable capacitive sensor technology. This product line marks the capstone in fulfilling a complete HVAC solution and boasts the same quality, delivery, and innovation demanded of all Setra products.

Features

Key component of comprehensive HVAC/R solution

The Setra humidity/temperature solution is an important part of our overall HVAC/R solution which also includes pressure and current. This bundle of products has established Setra as a premiere HVAC manufacturer and a full-solution player for HVAC customers.

Robust, proven capacitive sensor

The unique pairing of Setra's proven capacitance measurement technology with its custom ASIC (used in thousands of pressure devices) ensures reliable measure of RH levels from 0 to 100%. As a result, customers will experience better resistance to contamination, longer stability, and minimal drift.

Attractive/ low profile enclosures

Design and aesthetics have always been considered an important ingredient in any new Setra product. The humidity family consists of three configurations: wall, duct, and outside air models. Great attention was given to the look of the wall mount, ensuring that it complements the décor of any building. It is a space conscious unit that takes up no more space than an electrical outlet. The duct and outside air models utilize a design that ensures ease of both assembly and probe removal for recalibration.

Three levels of RH accuracy - 2%, 3%, and 5%

There are three levels of accuracy available for Setra humidity sensors: 2%, 3%, and 5%. The sensors should not drift more than 1% annually but it is recommended that the sensor be checked each year to ensure high accuracy and dependability.

Field Serviceability

Replaceable sensor board = no calibration and greater accuracy

Depending on the environment in which it is being used, a transducer may drift over time and need to be either recalibrated or replaced. Costs associated with recalibration are often overlooked when selecting an RH transmitter. However, these costs can easily outweigh the original purchase price if not considered on the front end.

The Setra SRH series uses a highly accurate, reliable, and durable sensor. However, if replacement is needed, the interchangeable RH sensor module can be easily removed. These computer-calibrated sensor assemblies are cost effective and do not require skilled technicians to perform field servicing. No calibration is needed because each new sensor module is factory-calibrated before shipping. Another benefit for duct and outside air applications is the sensor module can be replaced without having to remove the unit and disconnect the wiring conduit.

Low cost of ownership

As mentioned above, the replaceable sensor assembly eliminates high labor costs associated with field calibration. These products were designed with the customer in mind by combining accuracy, dependability and accessibility into an overall cost effective solution.

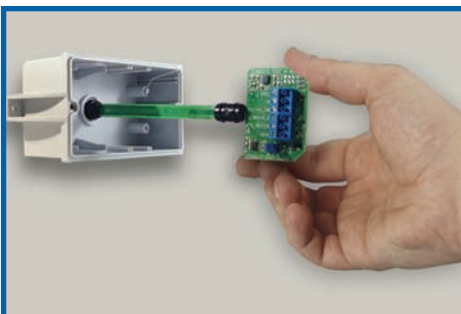

Patent No. 7,658,096

Simple Installation

Easy as 1-2-3

1) Mount the wall plate in desired position on wall (two screws).



2) Connect circuit board to wall plate.



3) Snap cover over assembly .



The assembly for the duct and outside air mounts is similar and outlined in easy-to-follow steps in the installation instructions.

Applications

- HVAC/R Control
- Indoor Air Quality (IAQ)
- Laboratories
- Antiquities Preservation

Features

- Key part of comprehensive HVAC solution package (i.e. humidity, pressure and current)
- Active Temperature with Jumper-Selectable Tspan Ranges of 40°C, 50°C and 60°C
- Three levels of RH accuracy: 2%, 3%, and 5%
- Excellent reliability via unique, proven, and established ASIC technology
- Robust, proven capacitive sensor technology
- Easy field-serviceability
- Low cost of ownership
- High aesthetic/ low profile wall-mount enclosure
- Quick-mount, 2-screw install w/ plug-in terminal wiring
- 1 year warranty on sensor; 3 year warranty on rest of unit.
- CE and RoHS Compliant

**Now Features
Active
Temperature
Sensing**

When it comes to a product to rely on - choose the SRH.

When it comes to a company to trust - choose Setra.

setra
ISO-9001 Certified

800-257-3872

Visit Setra Online:
<http://www.setra.com>

Specifications

RH Performance Data

Sensing Element	Capacitive Polymer
Humidity Operating Range	0 to 99% RH (Non-condensing)
Accuracy @ 68°F (20°C)	2%, 3%, 5%†
Hysteresis	<1.5%
Repeatability	<0.5%
Long Term Stability	<1% /Year @ 68°F (20°C), 50%RH

†5% units available only with passive temperature option.

Electrical Data

Signal Outputs	4 to 20 mA
Current (2-Wire)	4 to 20 mA
Field-Selectable Voltage (3-Wire)	0 to 5 VDC, 0 to 10 VDC,
Excitation	13.5 to 30 VDC (10VDC Output)
	12 to 30 VDC (4-20mA, 5VDC Output)
Maximum Load (Current Only)	$\Omega = (\text{Supply} - 10) \div 0.02$
Electrical Terminations	Pluggable Terminal Block (5mm Pitch)
Wiring Protection	Reverse Excitation
CE Compliance	EMC Directive 2004/108/EC

Temperature Sensing Options (Passive)

T1: Thermistor	NTC 10K Ω @ 77°F/25°C (Direct Connect) Type II
T2: RTD Output	1000 Ω @ 32°F/0°C (Direct Connect)
	385 Platinum Curve

Temperature Sensing Options (Active)

T3: Ranges °F (°C)	-58 to 140 (-50 to 60) ³
Accuracy @ 68°F (20°C) Typ. @ 50%	±1.1 (±0.6) *
T5: °F (°C)	+14 to 140 (-10 to 60) ³
Accuracy @ 68°F (20°C) Typ. @ 50%	±0.7 (±0.4) *

Signal Output Options	(includes humidity output)
Current	4 to 20 mA,
Field-Selectable Voltage	0 to 5 VDC, 0 to 10 VDC

* Excitation: 24 VDC ± 10%

Environmental Data

Operating Temperature °F (°C)	-40 to 140 (-40 to 60)
Storage Temperature °F (°C)	-40 to 158 (-40 to 70)
Moisture Resistance	IP65, NEMA-4 (Duct & Outside Air)
Solar	UV Resistant (Outside Air)
Flammability Rating	94-V0
Compliance	RoHS Compliant, CE Compliant

Physical Description

Enclosure Materials:	
Wall Mount	ABS 94-V0
Duct & Outside Air	Polycarbonate 94-V0
Probe (Duct & Outside Air)	Aluminum
Weather Shield	Porous Polyethylene
Sensor Tip Filter	70 Micron Polypropylene
Dimensions	See Dimension Drawings

Specifications subject to change without notice.

Dimension Drawings

Wall Mount

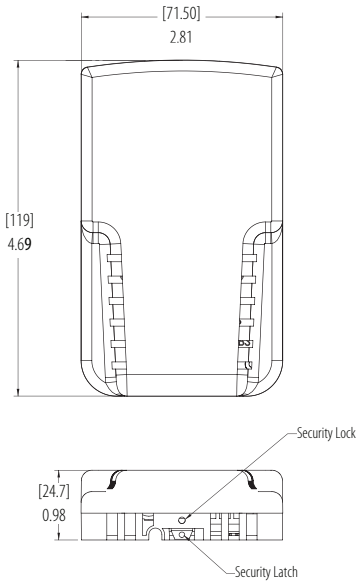

Duct Mount

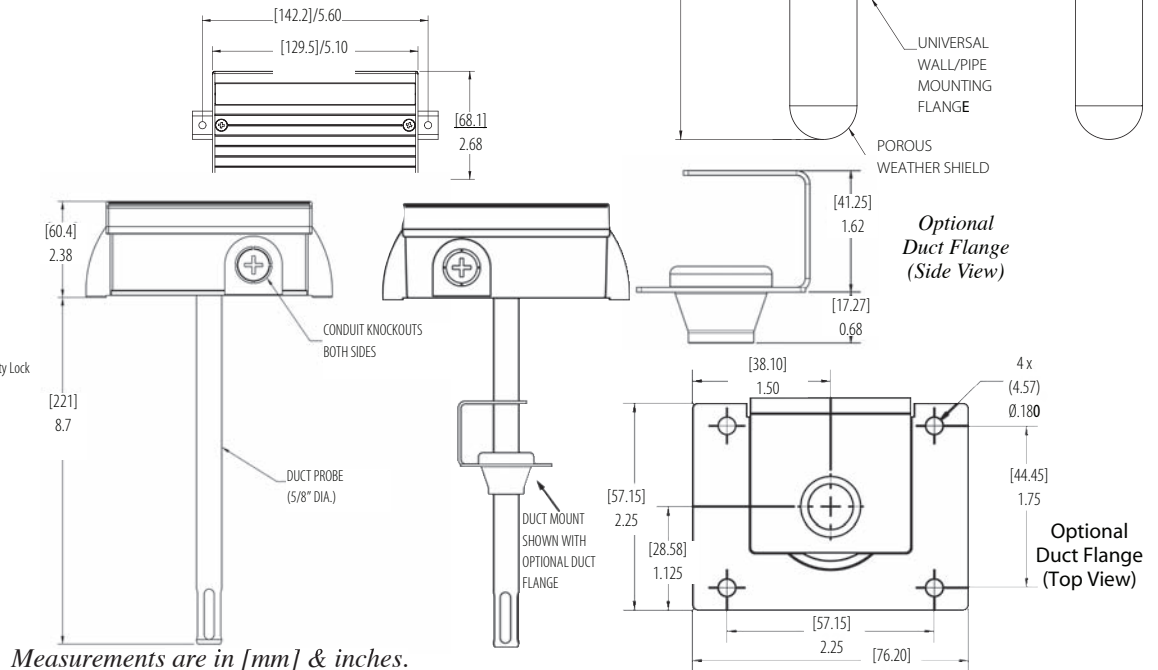

Measurements are in [mm] & inches.

Ordering Information (Code all blocks in table)

Example: Part No. SRH1-2P-W-11-T0-N-C = Wall-mount, 2% RH accuracy, 4-20 mA output, RH only, NIST Calibration Certificate

S	R	H	1							
Model	Accuracy	Configuration	Outputs	Temperature Outputs	Display⁴	Options				
SRH1 = SRH	2P = 2% 3P = 3% 5P = 5% ⁶	W = Wall ¹ D = Duct O = Outside Air	11 = 4-20 mA 2C = 0-5 or 0-10 VDC ² (user-selectable)	T0 = None (RH only) T1 = 10K Ω Thermistor (Passive) T2 = 1000 Ω RTD (Passive) T3 = -58 to 140°F (-50 to 60°C [Active]) ^{3,5,6} T5 = +14 to 140°F (-10 to 60°C [Active]) ^{3,5,6}	N = None	C = NIST Certificate of Conformance				
Replacement Sensor Assembly:										
Example: Part No. SRH3-2P-T0 = 2% accuracy, RH only	S	R	H	3						
	Model	Accuracy	Temperature Outputs							
	SRH3 = SRH ⁶	2P = 2% 3P = 3% 5P = 5% ⁶	T0 = None (RH only) T1 = 10K Ω Thermistor (Passive) T2 = 1000 Ω RTD (Passive) T3 = -58 to 140°F (-50 to 60°C [Active]) ⁵ T5 = +14 to 140°F (-10 to 60°C [Active]) ⁵							

- NOTES:
- 1 Wall (w) configuration not available with T3 Temperature option.
 2. Voltage outputs (2C) are factory configured for 0 to 5 VDC operation. User-selectable jumper for 0 to 10 VDC operation.
 3. Tspan jumper factory configured for 60°C. User-selectable Tspan for 40°C and 50°C option provided
 4. Display option available ONLY in Wall mount configuration
 5. SRH1 units originally ordered with either a T3 or T5 temperature option MUST be replaced with the same T(x) version.
 6. 5% accuracy units not available with active temperature option.

While we provide application assistance on all Setra products, both personally and through our literature, it is the customer's responsibility to determine the suitability of the product in the application.

159 Swanson Road, Boxborough, MA 01719/Tel: 978-263-1400;
Toll Free: 800-257-3872; Fax: 978-264-0292; email: sales@setra.com

