

Form 3032
Edition 4 ©July 1993
Updated Jan. 1994

MIC 8200

Installation, Wiring, Operation Manual

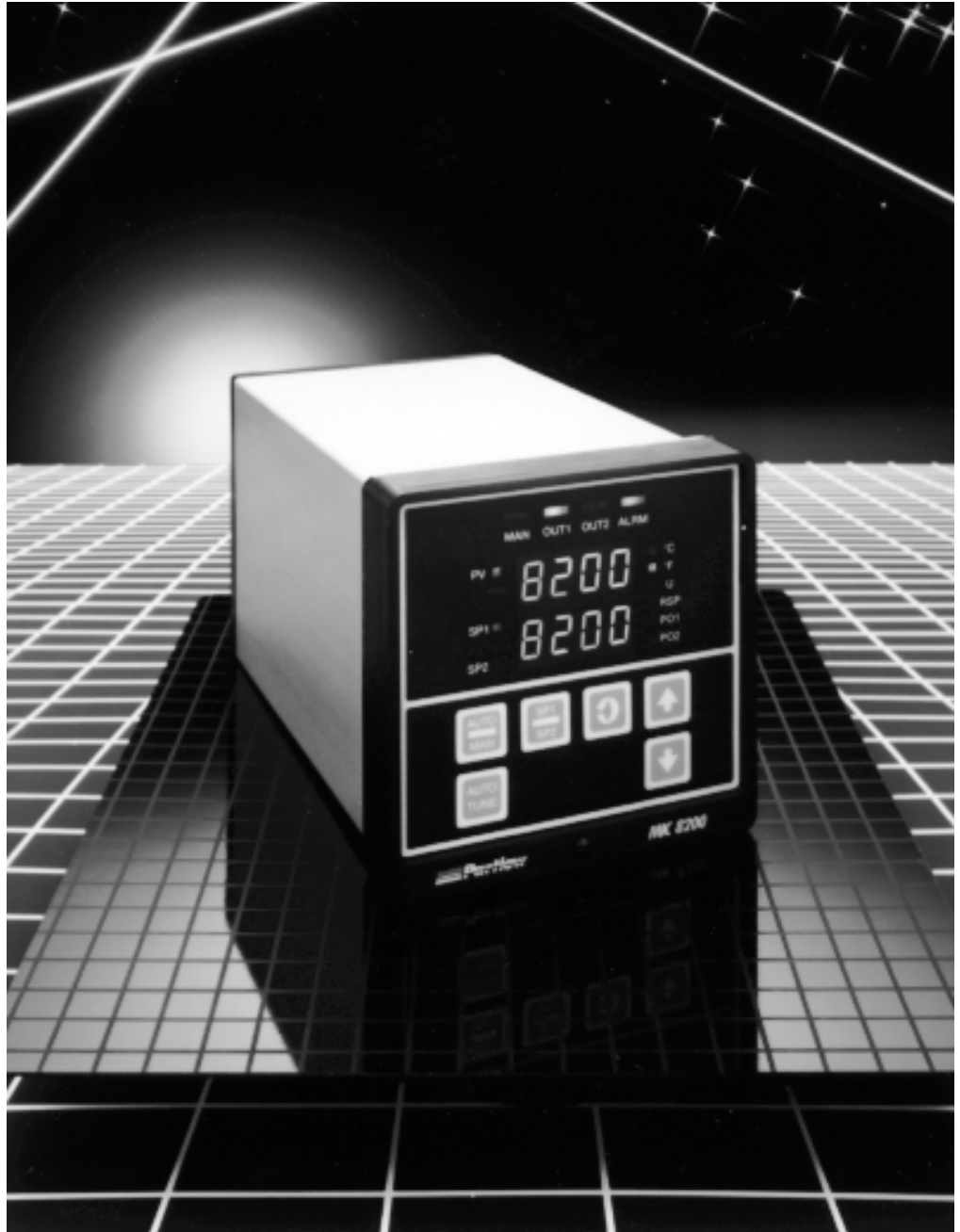

Information in this installation, wiring, and operation manual is subject to change without notice. One manual is provided with each instrument at the time of shipment. Extra copies are available at the price published on the front cover.

Copyright © July 1993, all rights reserved. No part of this publication may be reproduced, transmitted, transcribed or stored in a retrieval system, or translated into any language in any form by any means without the written permission of the factory.

This is the Fourth Edition of the manual. It was written and produced entirely on a desk-top-publishing system. Disk versions are available by written request to the factory - Advertising and Publications Department.

We are glad you decided to open this manual. It is written so that you can take full advantage of the features of your new dual display process controller.

NOTE

It is strongly recommended that factory equipped applications incorporate a high or low limit protective device which will shut down the equipment at a preset process condition in order to preclude possible damage to property or products.

Table of Contents

SECTION 1 - GENERAL	Page Number
1.1 Product Description	5
SECTION 2 - INSTALLATION & WIRING	
2.1 Installation and Wiring	7
2.2 Input Connections	8
2.3 Output Connections	13
SECTION 3 - CONFIGURATION & OPERATION	
3.1 Configuration and Operation	21
3.2 Operation Summary	22
3.3 Configuration Summary	23
3.4 Auto Tune Method	36
3.5 Manual Tuning Method	39
SECTION 4 - CONTROL CAPABILITY	
4.1 Control Capability	40
4.2 Control Responses	40
4.3 Direct/Reverse Operation of Control Outputs	40
4.4 On-Off Control	41
4.5 Time Proportioning Control	41
4.6 Current Proportioning Control	41
4.7 Position Proportioning Control	41
4.8 Dual Output Control	43
4.9 Manual Operation of Proportional Outputs	44
4.10 Automatic Transfer Function	44
4.11 Setpoint Adjustments	45
SECTION 5 - SERVICE	
5.1 Service	48
5.2 Calibration	48
5.3 Test Mode	52
5.4 Troubleshooting and diagnostics	56
APPENDICES	
A - Board Layout - Jumper Positioning	
Figure A-1 Power Supply Board	64
Figure A-2 Processor Board	65
Figure A-3 Option Board	66, 67
B - Glossary of terms	68
C - Model Number Hardware Matrix Details	73
D - Specifications	74
E - Software Record/Reference Sheet	77
Warranty	Inside back cover

FIGURES & TABLES

Figure 1-1	Controller Display Illustration	5
Figure 2-1	Panel Opening Sizes and Installation	7
Figure 2-2	Noise Suppression	9
Figure 2-3	Noise Suppression	10
Figure 2-4	Wiring Label	12
Figure 2-5	AC Power	13
Figure 2-6	Thermocouple Input	13
Figure 2-7	RTD Input	14
Figure 2-8	Volt, mV, mADC Input	14
Figure 2-9	24 Volt Transmitter Power Supply	15
Figure 2-10	Remote Setpoint Input	16
Figure 2-11	Remote Setpoint Selection	17
Figure 2-12	Remote Digital Comm. 7 & 8	17
Figure 2-13	Remote Digital Comm. G & H	18
Figure 2-14	Relay Output	18
Figure 2-15	SSR Driver Output	19
Figure 2-16	mADC Output	20
Figure 2-17	Position Proportioning Output	20
Figure 3-1	Front Panel	21
Figure 4-1	Proportional Bandwidth effect on Output	42
Figure 4-2	Dual Proportional Outputs	43
Figure 4-3	Setpoint Ramp Rate Example	45
Figure 4-4	Re-transmission Example	46
Table 3-1	Enable Mode Configuration Procedures	24
Table 3-2	Program Mode Configuration Procedures	29
Table 3-3	Tune Mode Configuration Procedures	35
Table 5-1	Calibration Procedures	48
Table 5-2	Test Procedures and Description	53

FLOW CHARTS

Flow - Calibration	49
Flow - Enable Mode	25
Flow - Program Mode	26
Flow - Test	52
Flow - Tune Mode	34
Flow - Setpoint Select	44

Product Description 1.1

1.1.1 GENERAL

This instrument is a microprocessor based single loop controller capable of measuring, displaying and controlling temperature, pressure, flow, and level from a variety of inputs. Most heating outputs are easily tuned using the instrument's Auto Tune function with several choices for control algorithms and control responses.

Control functions, alarm settings and other parameters are easily entered through the front keypad. All user's data can be protected from unauthorized changes with it's Enable mode security system. Battery back-up protects against data loss during AC power outages.

The input is user configurable to directly connect to either thermocouple, RTD, mVDC, VDC or mADC inputs. Thermocouple and RTD linearization, as well as thermocouple cold junction compensation is performed automatically. The sensor input is isolated. The instrument can be specified to operate on either 115VAC or 230VAC power at 50/60Hz. It is housed in an extruded aluminum enclosure suitable for panel mounting and may be surface mounted using an optional adaptor. For installation in washdown areas, a watertight cover is available (see the instrument price list order matrix).

FIGURE 1-1

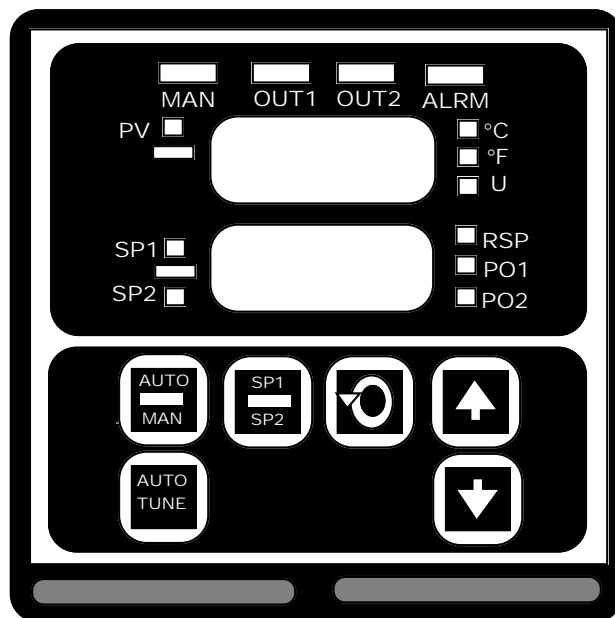

1.1.2 DISPLAYS

Each instrument is provided with dual digital displays and status indicators as shown in Figure 1-1. The upper digital display is programmable to show the process variable or the deviation from setpoint value. The lower digital display will be the active setpoint value or the percentage of the proportional output indicated by the indicator light. Status indication is as shown (Figure 1-1). Display resolution is programmable for 0 to 3 decimal places depending upon the input type selected.

1.1.3 CONTROL

The instrument can be programmed for on-off, time proportioning, current proportioning, or position proportioning control implementations depending on the output(s) specified for the instrument in the model number. The Auto Tune function can be used for a heating output assigned to output 1 at the Setpoint 1 value. A second control output is an available option. Proportional control implementations are provided with fully programmable separate PID parameters.

1.1.4 ALARM

Alarm indication is standard on all instruments. Alarm type may be set as PROCESS DIRECT or REVERSE (High or Low), DEVIATION DIRECT or REVERSE (Above or Below setpoint), or DEVIATION BAND TYPE (Closed or Open within the band). Alarm status is indicated by LED. An alarm output can be provided by assigning any output(s) SPST relay(s) or SSR Driver(s) to the alarm.

1.1.5 PROCESS VALUE RE-TRANSMISSION OUTPUT

If an instrument is specified with a mA/DC current output, this output may be programmed to operate as a process value re-transmission output (range scaled by user). If an output is used as a process value output, it is not available for use as a control output.

Installation and Wiring 2.1

Prior to proceeding with installation, verify the AC power input required by the instrument. AC power input is either 115 VAC or 230 VAC and is specified in the model number and on the wiring label affixed to the instrument housing. See Figure 2-4 (page 12) for a wiring label description.

230 VAC models may be converted to 115 VAC operation by the user by changing the position of jumpers soldered on the Power Supply Board, see Appendix A-1 (page 50) for details. (Note: 115VAC units cannot be field converted to 230VAC)

Electrical code requirements and safety standards should be observed and installation performed by qualified personnel.

The electronic components of the instrument may be removed from the housing during installation. To remove the components, loosen the locking screw located in the lower center of the instrument's front panel. Pull the entire instrument straight out of the housing. During re-installation, the vertically mounted circuit boards should be properly aligned in the housing. Be sure that the instrument is installed in the original housing. This can be verified by matching the serial number on the unit to the serial number on the housing. (Serial numbers are located on the inside of the housing enclosure and on the label on the underside of the front panel). This will insure that each instrument is accurate to its published specifications. The ambient compensator on the rear of the housing enclosure is calibrated to the electronics of the instrument at the factory.

Recommended panel opening sizes are illustrated below (Figure 2-1). After the opening is properly cut, insert the instrument housing into the panel opening. Insert the two panhead screws provided, through the holes in the mounting bracket into the holes in the rear of the instrument as shown in Figure 2-1. Firmly tighten the screws. Instruments are shipped standard for panel mounting. To surface mount, an adaptor is required and should be specified when ordering. For installation in wash-down areas, a watertight cover is available.

FIGURE 2-1 PANEL OPENING SIZES AND INSTALLATION

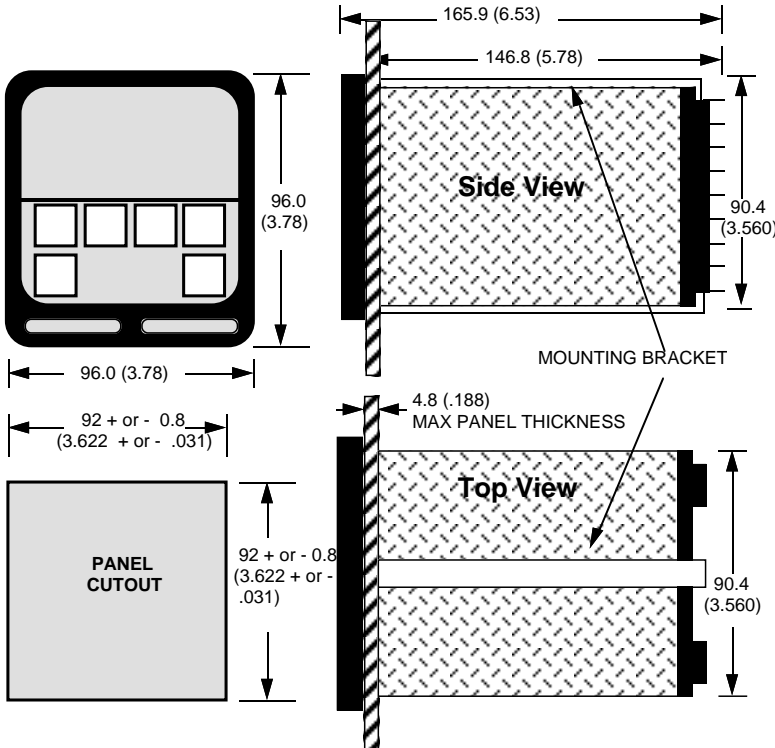

DIMENSIONS ARE IN MM (IN)

Preparation for Wiring 2.2

2.2.1 WIRING GUIDELINES

Electrical noise is a phenomenon typical of industrial environments. The following are guidelines that must be followed to minimize the effect of noise upon any instrumentation.

2.2.1.1 INSTALLATION CONSIDERATIONS

Listed below are some of the common sources of electrical noise in the industrial environment:

- Ignition Transformers
- Arc Welders
- Mechanical contact relay(s)
- Solenoids

Before using any instrument near the devices listed, the instructions below should be followed:

1. If the instrument is to be mounted in the same panel as any of the listed devices, separate them by the largest distance possible. For maximum electrical noise reduction, the noise generating devices should be mounted in a separate enclosure.
2. If possible, eliminate mechanical contact relay(s) and replace with solid state relays. If a mechanical relay being powered by an instrument output device cannot be replaced, a solid state relay can be used to isolate the instrument.
3. A separate isolation transformer to feed only instrumentation should be considered. The transformer can isolate the instrument from noise found on the AC power input.
4. If the instrument is being installed on existing equipment, the wiring in the area should be checked to insure that good wiring practices have been followed.

2.2.1.2 AC POWER WIRING

Earth Ground

The instrument includes noise suppression components that require an earth ground connection to function. To verify that a good earth ground is being attached, make a resistance check from the instrument chassis to the nearest metal water pipe or proven earth ground. This reading should not exceed 100 ohms. Use a 12 gauge (or heavier) insulated stranded wire.

Neutral (For 115VAC)

It is good practice to assure that the AC neutral is at or near ground potential. To verify this, a voltmeter check between neutral and ground should be done. On the AC range, the reading should not be more than 50 millivolts. If it is greater than this amount, the secondary of this AC transformer supplying the instrument should be checked by an electrician. A proper neutral will help ensure maximum performance from the instrument.

2.2.1.3 WIRE ISOLATION

Four voltage levels of input and output wiring may be used with the unit:

- Analog input or output (i.e. thermocouple, RTD, VDC, mVDC or mADC)
- SPST Relays
- SSR driver output
- AC power

The only wires that should be run together are those of the same category. If they need to be run parallel with any of the other lines, maintain a minimum 6 inch space between the wires. If wires must cross each other, do so at 90 degrees. This will minimize the contact with each other, do so at 90 degrees. This will minimize the contact with each other and reduces "cross talk". "Cross talk" is due to the EMF (Electro Magnetic Flux) emitted by a wire as current passes through it. This EMF can be picked up by other wires running the same bundle or conduit.

In applications where a High Voltage Transformer is used, (i.e. ignition systems) the secondary of the transformer should be isolated from all other cables.

This instrument has been designed to operate in noisy environments, however, in some cases even with proper wiring it may be necessary to suppress the noise at its source.

2.2.1.4 USE OF SHIELDED CABLE

Shielded cable helps eliminate electrical noise being induced on the wires. All analog signals should be run with shielded cable. Connection lead length should be kept as short as possible, keeping the wires protected by the shielding. The shield should be grounded at one end only. The preferred grounding location is the sensor, transmitter, or transducer.

2.2.1.5 NOISE SUPPRESSION AT THE SOURCE

Usually when good wiring practices are followed, no further noise protection necessary. sometimes in severe electrical environments, the amount of noise is so great tht it has to be suppressed at the source. Many manufacturers of relays, contactors, etc., supply "surge suppressors" which mount on the noise source.

For these devices that do not have surge suppressors supplied, RC (resistance-capacitance) networks and/or MOC (metal oxide varistors) may be added.

Inductive Coils - MOV's are recommended for transient suppression in inductive coils connected in parallel and as close as possible to the coil. See Figure 2-2. Additional protection may be provided by adding an RC network across the MOV.

FIGURE2-2

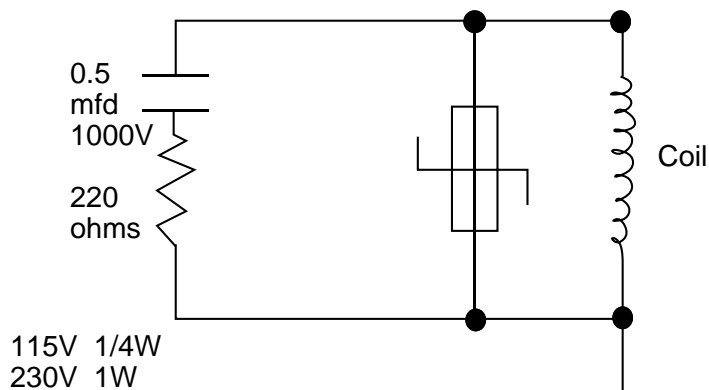

Contacts - Arcing may occur across contacts when the contact opens and closes. This results in electrical noise as well as damage to the contacts. Connecting a RC network properly sized can eliminate this arc.

For circuits up to 3 amps, a combination of a 47 ohm resistor and 0.1 microfarad capacitor (1000 volts) is recommended. For circuits from 3 to 5 amps, connect 2 of these in parallel. See Figure 2-3, page 10.

FIGURE 2-3

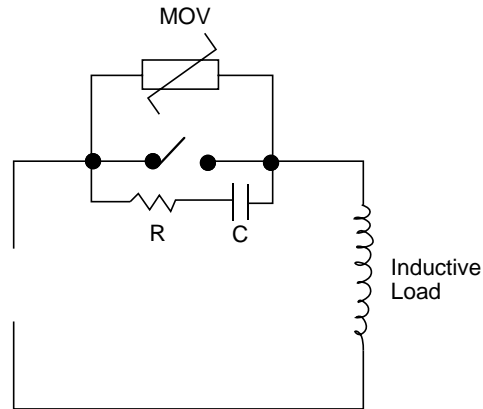

2.2.2 SENSOR PLACEMENT (Thermocouple or RTD)

Two wire RTD's should be used only with lead lengths less than 10 feet.

If the temperature probe is to be subjected to corrosive or abrasive conditions, it should be protected by the appropriate thermowell. The probe should be positioned to reflect true process temperature:

- In liquid media - the most agitated area.
- In air - the best circulated area.

THERMOCOUPLE LEAD RESISTANCE

Thermocouple lead length can affect instrument accuracy since the size (gauge) and the length of the wire affect lead resistance.

To determine the temperature error resulting from the lead length resistance, use the following equation:

$$T_{err} = TLe * L \quad \text{where; } TLe = \text{value from appropriate table below}$$

L = length of leadwire in thousands of feet

TABLE 1

Temperature error in °C per 1000 feet of Leadwire									
AWG No.	Thermocouple Type:								
	J	K	T	R	S	E	B	N	C
10	.34	.85	.38	1.02	1.06	.58	7.00	1.47	1.26
12	.54	1.34	.61	1.65	1.65	.91	11.00	2.34	2.03
14	.87	2.15	.97	2.67	2.65	1.46	17.50	3.72	3.19
16	1.37	3.38	1.54	4.15	4.18	2.30	27.75	5.91	5.05
18	2.22	5.50	2.50	6.76	6.82	3.73	44.25	9.40	8.13
20	3.57	8.62	3.92	10.80	10.88	5.89	70.50	14.94	12.91
24	8.78	21.91	9.91	27.16	27.29	14.83	178.25	37.80	32.64

TABLE 2

Temperature Error in °F per 1000 feet of Leadwire									
AWG No.	Thermocouple Type:								
	J	K	T	R	S	E	B	N	C
10	.61	1.54	.69	1.84	1.91	1.04	12.60	2.65	2.27
12	.97	2.41	1.09	2.97	2.96	1.64	19.80	4.21	3.66
14	1.57	3.86	1.75	4.81	4.76	2.63	31.50	6.69	5.74
16	2.47	6.09	2.77	7.47	7.52	4.14	49.95	10.64	9.10
18	4.00	9.90	4.50	12.17	12.28	6.72	79.95	10.64	9.10
20	6.43	15.51	7.06	19.43	19.59	10.61	126.90	26.89	23.24
24	15.80	39.44	17.83	48.89	49.13	26.70	320.85	68.03	58.75

Example:

An MIC is to be located in a control room 660 feet away from the process. Using 16 AWG, type J thermocouple, how much error is induced?

$$T_{err} = TLe * L$$

TLe = 2.47 (°F/1000 ft) from Table 2

$$T_{err} = 2.47 (°F/1000 ft) * 660 ft$$

$$T_{err} = 1.6 °F$$

RTD LEAD RESISTANCE

Rtd lead length can affect instrument accuracy, since the size (gauge) and length of the wire affect lead resistance.

To determine the temperature error resulting from the lead length resistance, use the following equation:

$$T_{err} = TLe * L \quad \text{where; } TLe = \text{value from Table 3 if 3 wire RTD or Table 4 if 2 wire RTD}$$

L = length of lead wire in thousands of feet.

TABLE 3 3 Wire RTD

AWG No.	Error °C	Error °F
10	+/-0.04	+/-0.07
12	+/-0.07	+/-0.11
14	+/-0.10	+/-0.18
16	+/-0.16	+/-0.29
18	+/-0.26	+/-0.46
20	+/-0.41	+/-0.73
24	+/-0.65	+/-1.17

TABLE 4 2 Wire RTD

AWG No.	Error °C	Error °F
10	+/-5.32	+/-9.31
12	+/-9.31	+/-14.6
14	+/-13.3	+/-23.9
16	+/-21.3	+/-38.6
18	+/-34.6	+/-61.2
20	+/-54.5	+/-97.1
24	+/-86.5	+/-155.6

(Continued on next page)

(Continued from page 11)

Example:

An application uses 2000 feet of 18 AWG copper lead wire for a 3 wire RTD sensor. What is the worst case error due to this leadwire length?

$$T_{err} = TLe * L$$

$$TLe = +/- .46 (°F/1000 ft) \text{ from Table 3}$$

$$T_{err} = +/- .46 (°F/1000 ft) * 2000 ft$$

$$T_{err} = +/- 0.92°F$$

FIGURE2-4 WIRING LABEL

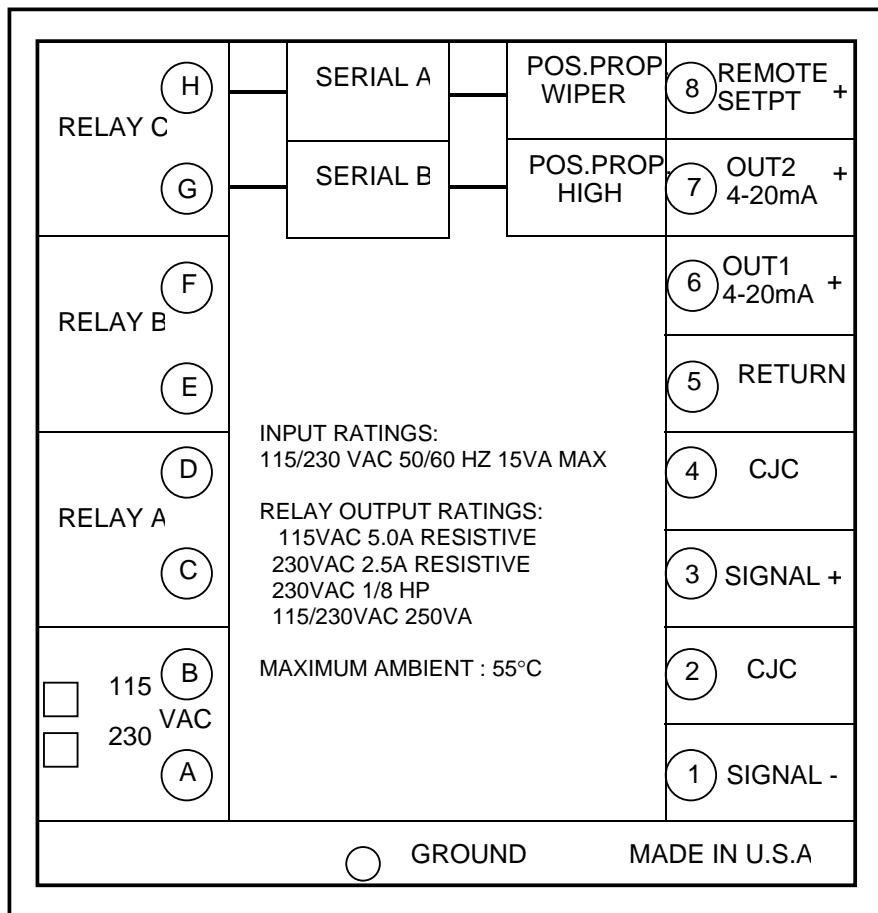

Input Connections 2.3

In general, all wiring connections are made to the instrument after it is installed. **Avoid electrical shock. AC power wiring must not be connected to the source distribution panel until all wiring connection procedures are completed.**

2.3.1 INPUT CONNECTIONS

FIGURE 2-5

AC Power

Connect 115 VAC hot and neutral to terminals B and A respectively as illustrated below. Connect 230 VAC as described below. Connect Earth ground to the ground screw as shown.

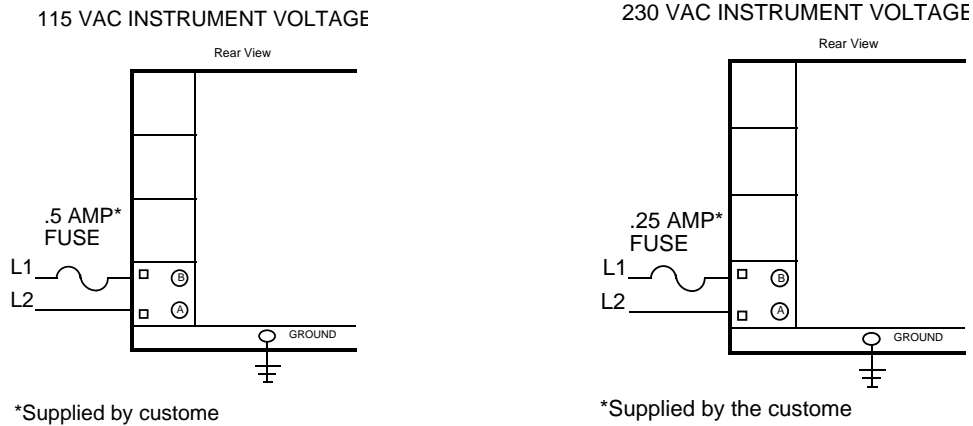

FIGURE 2-6

Thermocouple (T/C) Input

Make thermocouple connections as illustrated below. Connect the positive leg of the thermocouple to terminal 3, and the negative to terminal 1. For industrial environments with comparatively high electrical noise levels, shielded thermocouples and extension wire are recommended. Be sure that the input conditioning jumpers are properly positioned for a thermocouple input. See Appendix A-2 (page 65) and A-3 (page 66 and 67).

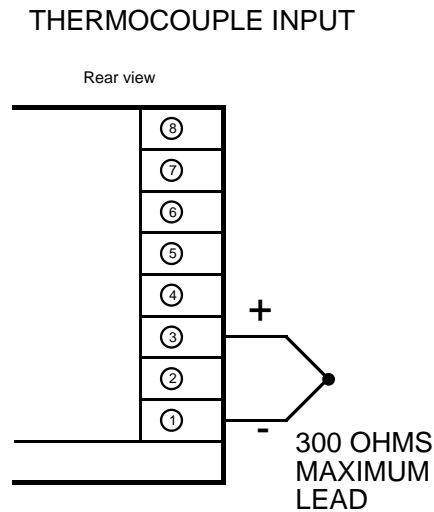

FIGURE 2-7

RTD Input

Make RTD connections as illustrated below. For a three wire RTD, connect the resistive leg of the RTD to terminal 3, and the common legs to terminal 1 and 5. For a two wire RTD, connect one wire to terminal 1 and the other wire to terminal 3 as shown below. A jumper wire supplied by the customer must be installed between terminals 1 and 5. Be sure that the input conditioning jumpers are properly positioned for an RTD input. See Appendix A-2 (page 65) and A-3 (page 66 and 67).

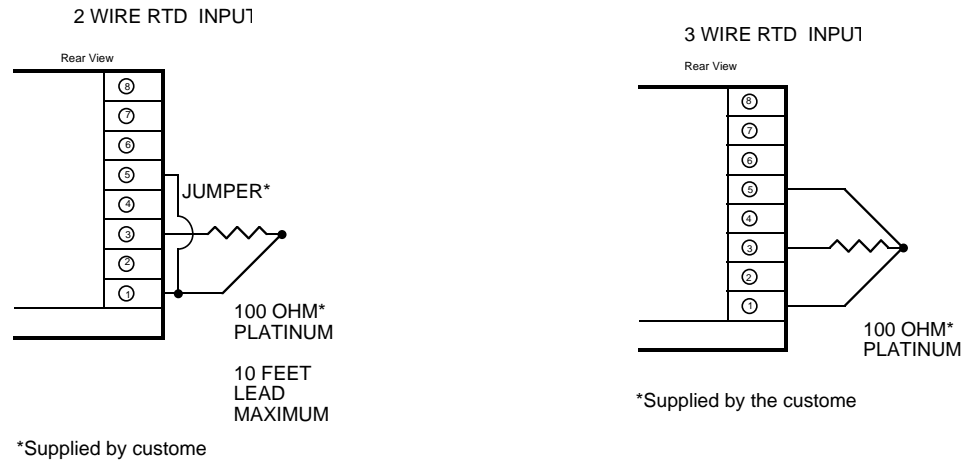
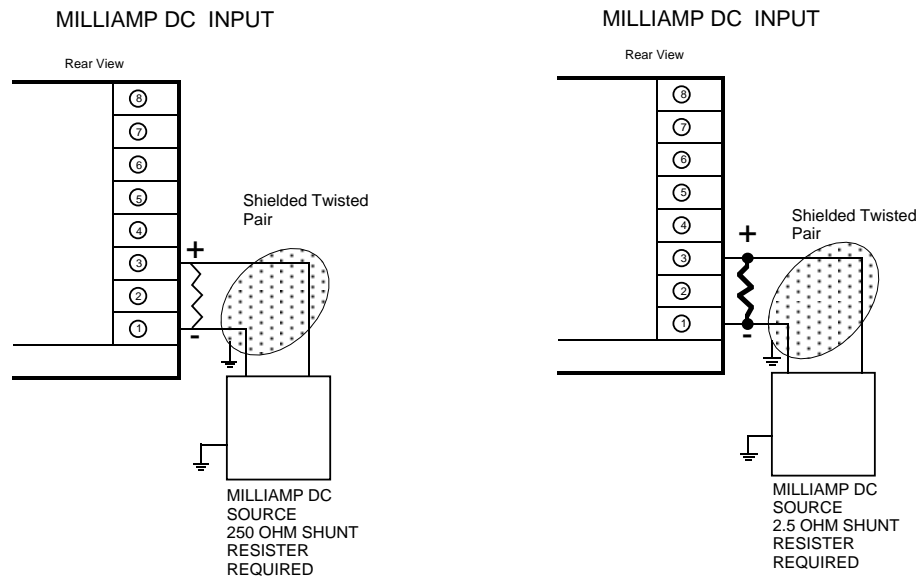

FIGURE 2-8

Volt, mV, mADC Input

Make volt, millivolt and milliamp connections as shown below. Terminal 3 is positive and terminal 1 is negative. Milliamp input requires a 250 ohm shunt resistor (supplied with the instrument) installed across the input terminals and by configuring the instrument for either 0 to 5 or 1 to 5 VDC input. If desired, milliamp DC input can be facilitated by installing an optional 2.5 ohm resistor across the input terminals and configuring the instrument for either 0 to 50 or 10 to 50 mVDC. Be sure that the input conditioning jumpers are properly positioned for the input type selected. See Appendix A-2 (page 65) and A-3 (page 66 and 67).



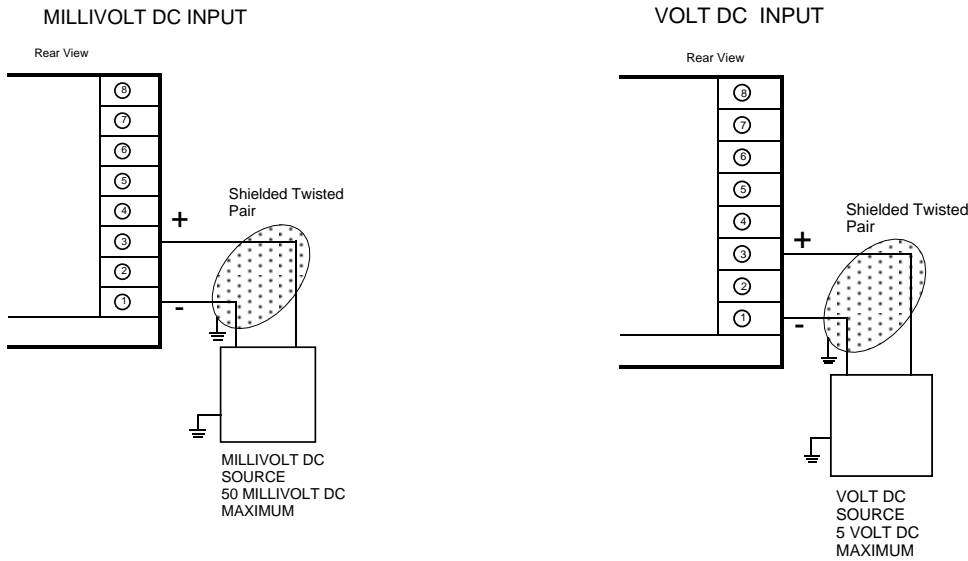

FIGURE2-9A

24 Volt Transmitter Power Supply (XP Option)

Make connections as shown below. Terminal 3 is positive (+) and terminal 1 is negative (-). Be sure the input conditioning jumpers are properly positioned for the input type selected. See Figure A-2 Processor Board, page 65, and Figure A-3 Option Board, page 66 or 67. Note the 250 ohm shunt resistor is not required.

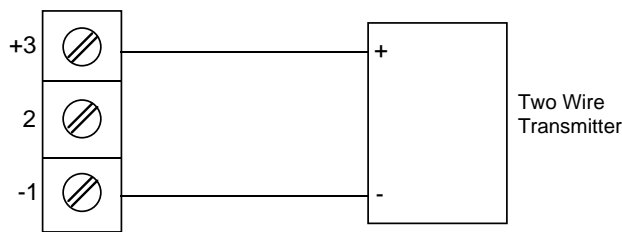

FIGURE2-9B

24 Volt Power Supply (XA Option)

Make connections as shown below. Terminal G is positive (+) and terminal H is negative (-). Be sure the input conditioning jumpers are properly positioned. See Figure A-2 Processor Board, page 65 and Figure A-3 Option Board, page 66 or 67.

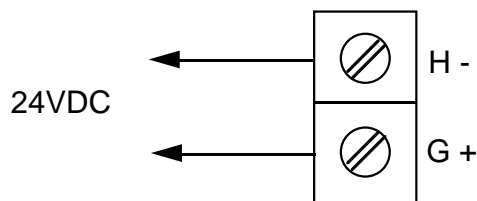
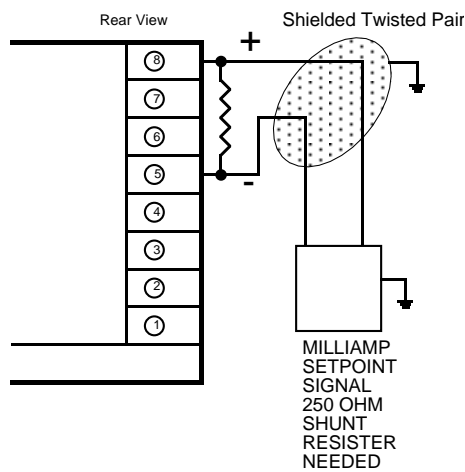

FIGURE2-10

Remote Setpoint Input - VDC and mADC and Potentiometer

Input connections are illustrated below. Terminal 8 is positive and terminal 5 is negative. The remote setpoint input can be configured for either 0 to 5VDC or 1 to 5 VDC input. Make sure that the voltage input matches the voltage configuration selected in the Program mode. For mA inputs, a 250 ohm shunt resistor must be installed between terminals 5 and 8. For remote setpoint using a potentiometer, JU1 on options board must be in MM/PP (see page 66 and 67).

CURRENT DC REMOTE SETPOINT



VOLT DC REMOTE SETPOINT

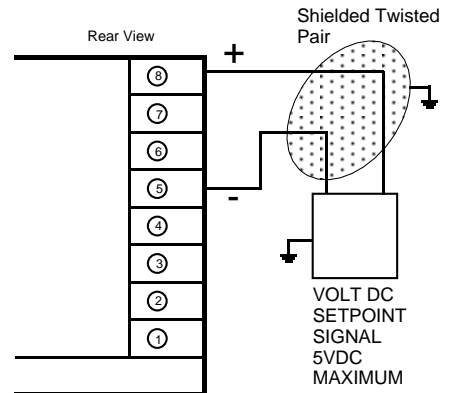

POTENTIOMETER

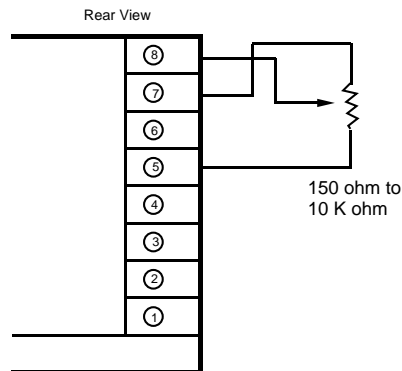

FIGURE2-11

Remote Setpoint Selection of one of two preset setpoint values (Optional)

A programmable feature allows for the setpoint value to be toggled between two preselected values when a dry contact closure is sensed between terminals 8 and 5. For more information see section 3 (page 21).

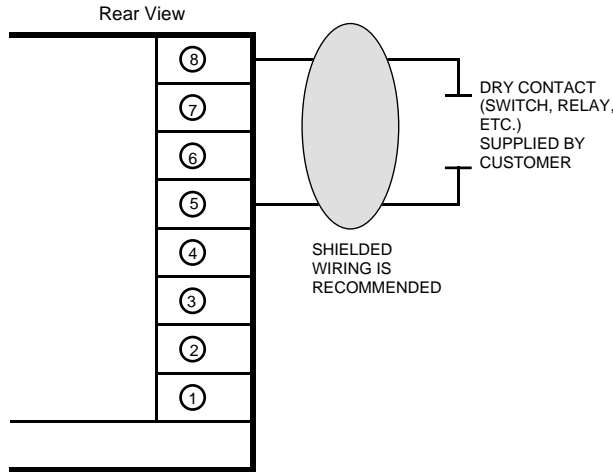

FIGURE2-12

Remote Digital Communications RS 485 Terminals 7 & 8 (Optional)

If the communications network continues on to other units, connect the shields together, but not to the instrument. A terminating resistor should be installed at the terminals of the last instrument in the loop. The shield should be grounded at the computer or the convertor box, if used. See the Protocol Manual (Form 2878) for more details on the use of the digital communications option.

DIGITAL COMMUNICATIONS CONNECTIONS - TERMINALS 7 & 8

Terminals 7 & 8 are used for communications when the model number is 82XYX3X, 82XYX5X where X = any valid number and Y = 0, 1, or 2. No Second Output 4-20mA

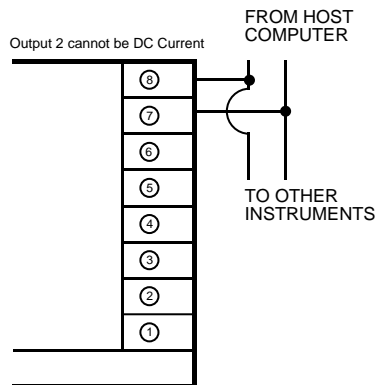

FIGURE 2-13

Alternate Remote Digital Communications RS 485 Terminals G & H (Optional)

If the communications network continues on to other units, connect the shields together, but not to the instrument. A terminating resistor should be installed at the terminals of the last instrument in the loop. The shield should be grounded at the computer or the convertor box, if used. See the Protocol Manual (Form 2878) for more details on the use of the digital communications option.

Terminals G & H are used for communications when the model number is 82XY04X, 82XY06X where X = any valid number and Y = 3, 4, or 5. Use when Second Output is 4-20mA.

DIGITAL COMMUNICATIONS CONNECTIONS - TERMINALS G & H

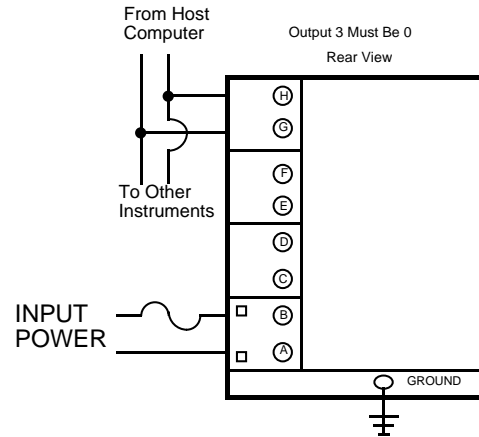

Output Connections 2.4

FIGURE 2-14

Relay Output

Connections are made to relay A as illustrated below. Connect relay(s) B & C (if present) in the same manner. Relay contacts are rated at 5 amp Resistive load 115 VAC.

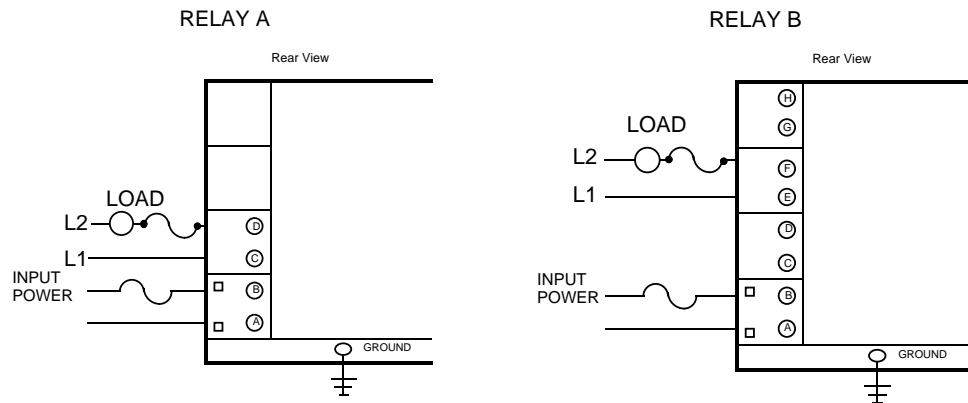

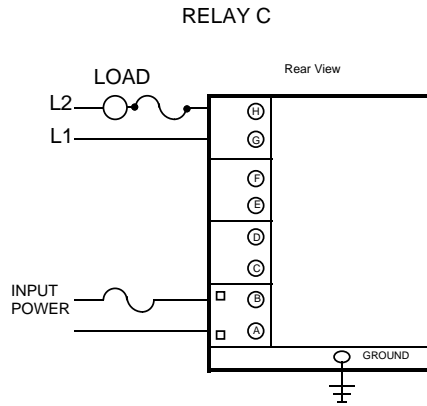
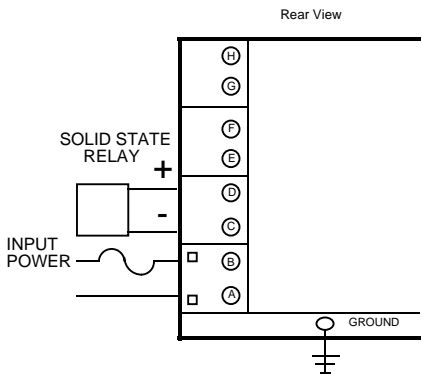

FIGURE2-15

SSR Driver Output

Connections are made to the solid state relay driver output located in the Relay A position as shown. The solid state relay driver is a 5 VDC current sink output type. Connect the solid state relay driver(s) in the Relay B and C position (if present) in the same manner.

SSR DRIVER (RELAY A)



SSR DRIVER (RELAY B)

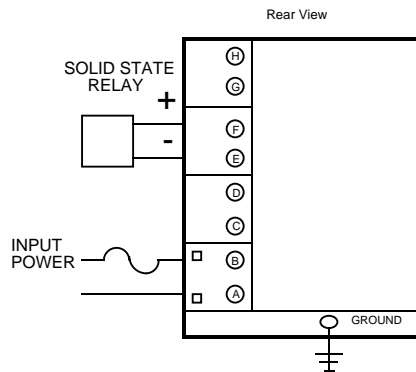

SSR DRIVER (RELAY C)

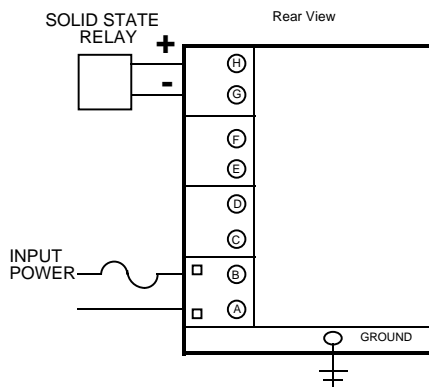
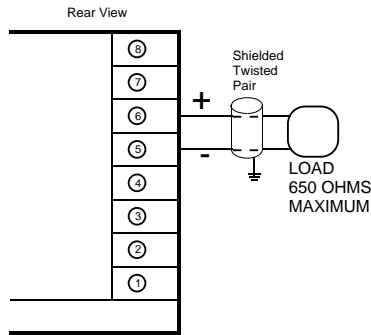

FIGURE2-16

mADC Output

Connections are made for current outputs 1 or 2 as shown below. Connect the positive lead to terminal 6 for Output 1 or terminal 7 for Output 2, the negative leads connect to terminal 5. Current outputs will operate up to 650 ohms maximum load. The current output(s) can be selected for either 4 - 20 mADC or 0 - 20 mADC. If dual current outputs are both used, connect the returns to terminal 5.

DC CURRENT OUTPUT 1



DC CURRENT OUTPUT 2

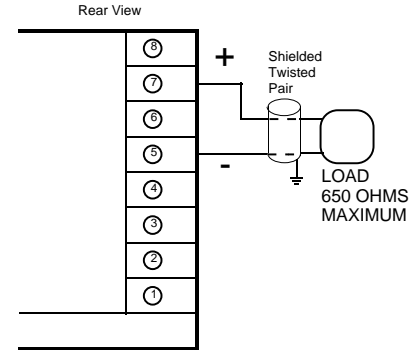
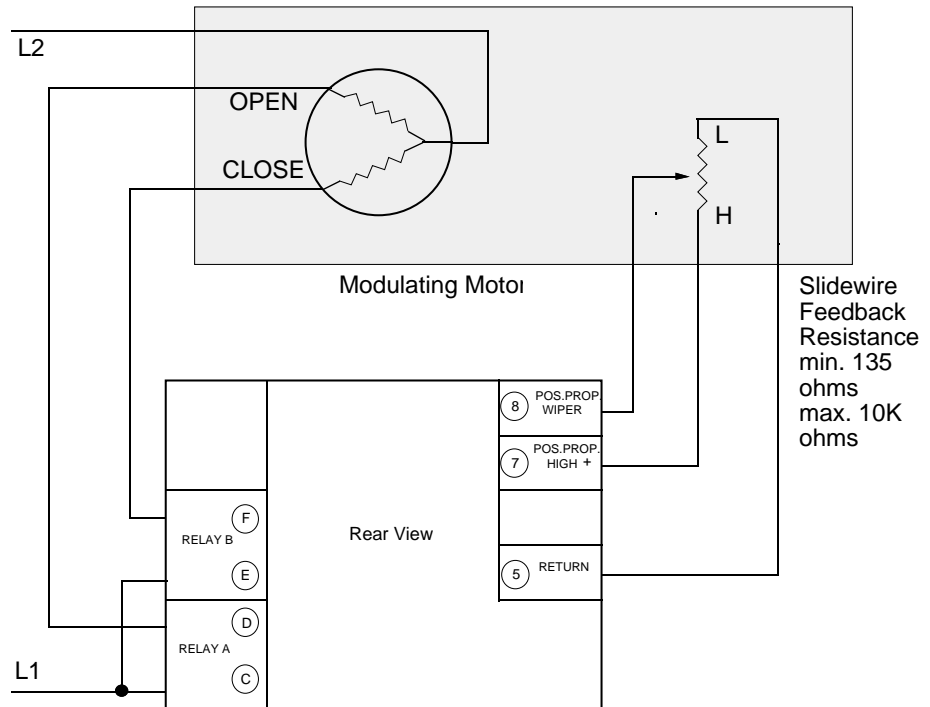

FIGURE2-17

Position Proportioning Output

The relay and slidewire feedback connections are made as illustrated below. The relay assigned to Output 1 will be used to drive the motor in the open direction and the relay assigned to Output 2 will be used to drive the motor in the closed direction. The minimum slidewire feedback resistance is 135 ohms, the maximum resistance is 10K ohms.



Configuration and Operation 3.1

3.1.1 POWERUPPROCEDURE

Verify all electrical connections have been properly made before applying power to the instrument.

If the instrument is being configured (set up) for the first time, it may be desirable to disconnect the controller output connections. The instrument will go into the Control mode following the power up sequence and the output(s) may turn on. During power up, the seven digit model number will be displayed. Next, the EPROM tab number will be displayed, followed by the software revision level. Instrument self test 1 through 3 will take place as they are displayed. After completion of the tests **Ctrl** will be displayed for 3 seconds. At this time another mode of operation may be selected by pressing the SCROLL key.

3.1.2 CONFIGURATIONPROCEDURE

Parameter selections and data entry are made via the front keypad. To ease configuration and operation, the user selectable features have been divided into several sections (modes). Data and parameter entries are made by stepping through each mode and making an appropriate response or entry to each step as necessary for the application.

FIGURE3-1

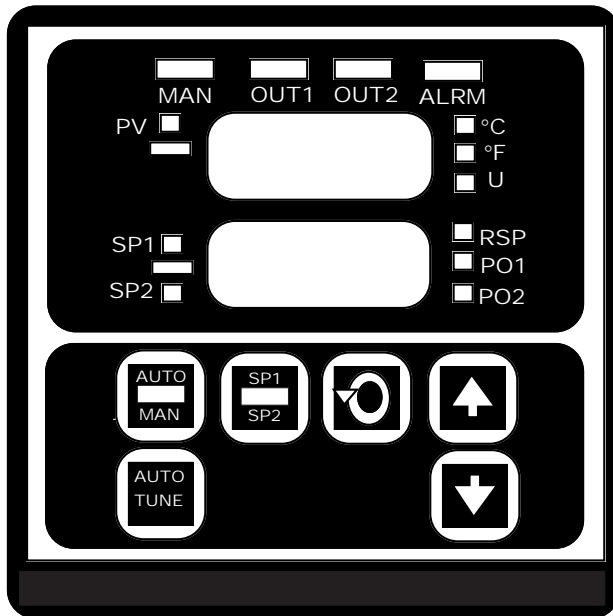

Operation Summary 3.2

3.2.1 KEYPAD OPERATION

AUTO/MANUAL KEY

This key is used to enter the Manual mode (Standby) of operation from the Control mode and visa versa.

AUTO TUNE KEY

This key is used to initiate the Auto Tuning of the Output 1 proportional output for heating applications. If Auto Tune is being performed, pressing this key will abort the Auto Tune function. The instrument will Auto Tune the process to control at the Setpoint 1 value.

SP1/SP2 KEY

This key is used to change the setpoint from one preselected value to the other preselected value.

SCROLL KEY

This key is used to:

1. Display enabled modes of operation
2. Display a mode parameter value
3. Advance display from a parameter value to the next parameter code
4. Exit some calibration/test functions
5. Used with other keys:
 - A. With UP key to view output percentages of proportional output(s)
 - B. With DOWN key
 1. On power up to alter model number
 2. Enter calibration /test functions
 3. To view output percentage of proportional Output 2

UP KEY

This key is used to:

1. Increase displayed parameter value
2. Increase setpoint (press and hold)
3. With a parameter code displayed
 - A. Press once to exit mode
 - B. Press twice to enter Control mode
4. Used with other keys
 - A. In Control mode with SCROLL key to view output percentage of proportional output 1.
 - B. With DOWN Key
 1. On power up resets instrument
 2. Lamp test (press and release)
 3. Enter Enable Mode (press and hold)

DOWN KEY

This key is used to:

1. Decrease displayed parameter value
2. Decrease setpoint (press and hold)
3. Enter modes
4. While in a mode, will sequence the parameter codes
5. Used with other keys
 - A. With SCROLL key
 1. On power up to alter model number
 2. Enter calibration/test functions
 3. To view the output percentage of proportional output 2
 - B. With UP key
 1. On power up resets instrument
 2. Lamp test (press and release)
 3. Enter enable mode (press and hold)

3.2.2 CONFIGURATION DISPLAYS

During configuration, the upper display shows the parameter codes. The lower digital display shows the parameter value. During operation, the upper display is used to indicate process value or deviation from setpoint. The lower display can be used to indicate setpoint value or proportional output percentage.

3.2.3 MODE SELECTION

If the instrument is in the Control mode, repeated depressions of the SCROLL key will cause the instrument to display the code corresponding to each mode that is enabled. To enter a mode, with the mode displayed, depress the DOWN key. Entry into any mode except the Control, Tune and Enable modes will cause the output(s) to turn off.

Configuration Summary 3.3

All configurable parameters are provided in Tables 3-1 thru 3-3 on the following pages. These tables illustrate the display sequence, parameter adjustment and factory setting for each step.

The instrument is provided with a “time-out” feature. If the instrument is in any mode, other than the Control mode, and no keypad activity takes place for 30 seconds, the mode will be exited automatically. The instrument will then display the code for the respective mode. If a mode code is displayed for five seconds with no key stroke activity the “time-out” will cause the instrument to return to the Control mode of operation.

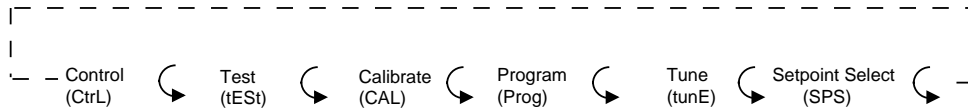

3.3.1 ENABLE MODE CONFIGURATION

The Enable Mode provides a means of enabling or disabling access to setpoint changes and each of the non-control modes. In the Enable mode, each mode except Control, will be displayed. Either “on” (enabled) or “oFF” (disabled) may be selected. See Table 3-1 (page 24) for the Enable mode procedure. For additional security the Enable mode may be locked out by using a hardware jumper, JU 2, located on the Processor board. See Appendix A-2 (page 65).

3.3.2 PROGRAM MODE CONFIGURATION

The Program mode is used to configure or re-configure the instrument. The input and output selections are made in the Program mode. All possible parameters are illustrated in Table 3-2 (page 29) for illustrative purposes. Only those parameters that are applicable to the hardware options chosen or to previous parameter selections will be displayed.

3.3.3 TUNE MODE CONFIGURATION

The Tune mode is used to adjust the tuning parameters and the alarm setting needed for operation of the instrument. If Auto Tuning is used to determine the parameters for the heating output (Output 1), those parameters in the Tune mode (except Cycle time) need not be configured.

TABLE 3-1 ENABLE MODE CONFIGURATION PROCEDURE

To enter the Enable mode, depress and hold the UP and DOWN keys. All display lamps will light, after ten seconds the upper display will read **EnAb**. If **EnAb** does not appear, check the position of the Enable mode jumper, JU 2, located on the Processor board (See Appendix A-2, page 65). The jumper must be in the unlocked position for the Enable mode to function. Release the keys and the upper display will then change to **EtSt**. Depress the SCROLL key to review the state (on or off) of the mode (will appear on the lower display). Use the UP key to enable a mode that is off. Use the DOWN key to disable a mode that is on. When all selections have been made, to exit the Enable mode depress the UP key with a mode code displayed **EtSt**, **ECAL**, etc.

STEP	DESCRIPTION	DISPLAY CODE	AVAILABLE FACTORY SETTINGS	YOUR SETTING	YOUR SETTING
1	Test Mode	EtSt	on or off	off	
2	Calibration Mode	ECAL	on or off	off	
3	Program Mode	EPro	on or off	on	
4	Tune Mode	Etun	on or off	on	
5	Standby Mode	ESby	on or off	on	
6	Setpoint Select	ESPS	on or off	off	
7	Setpoint Changes	ESPC	on or off	on	
8	Auto Tune	EAtn	on or off	on	

If Standby is disabled and Auto Tune Abort is 0 or 1, then Standby is automatically turned on and cancels setting in the Enable mode.

ENABLEMODEFLOWCHART

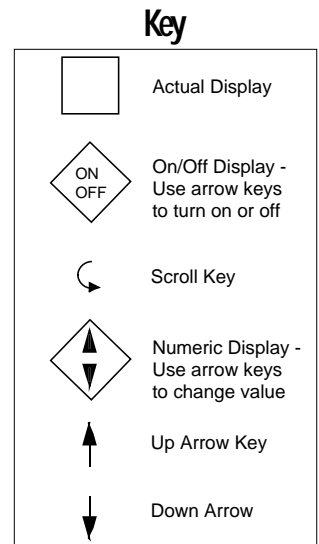
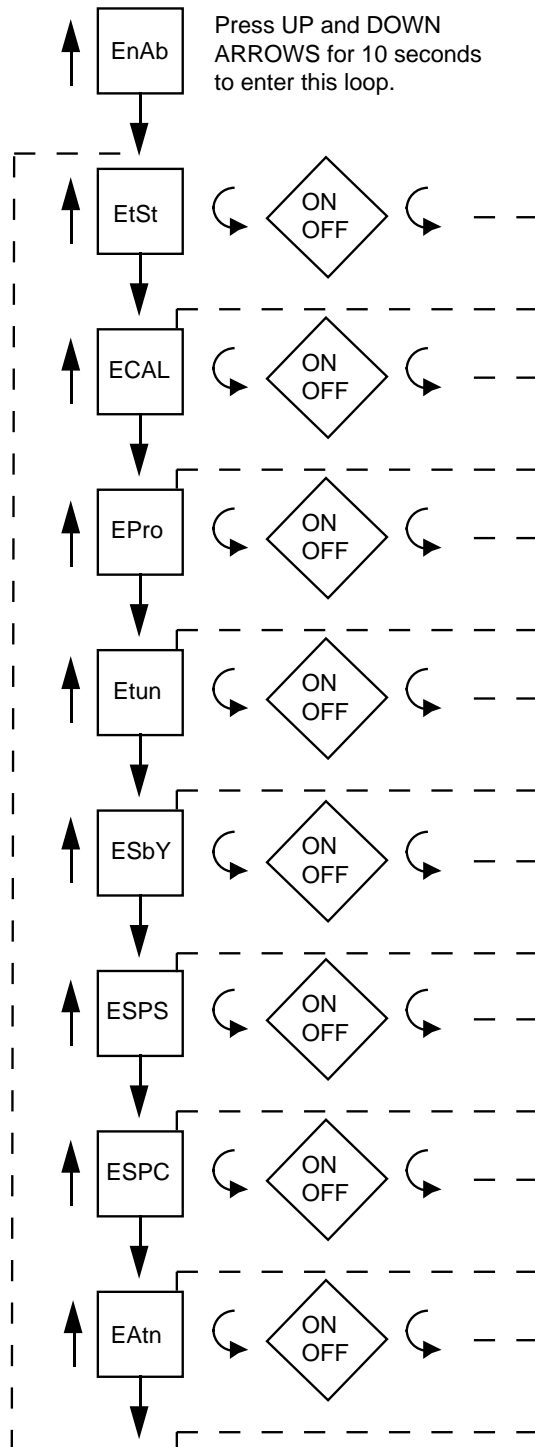

PROGRAM/MODEFLOWCHART

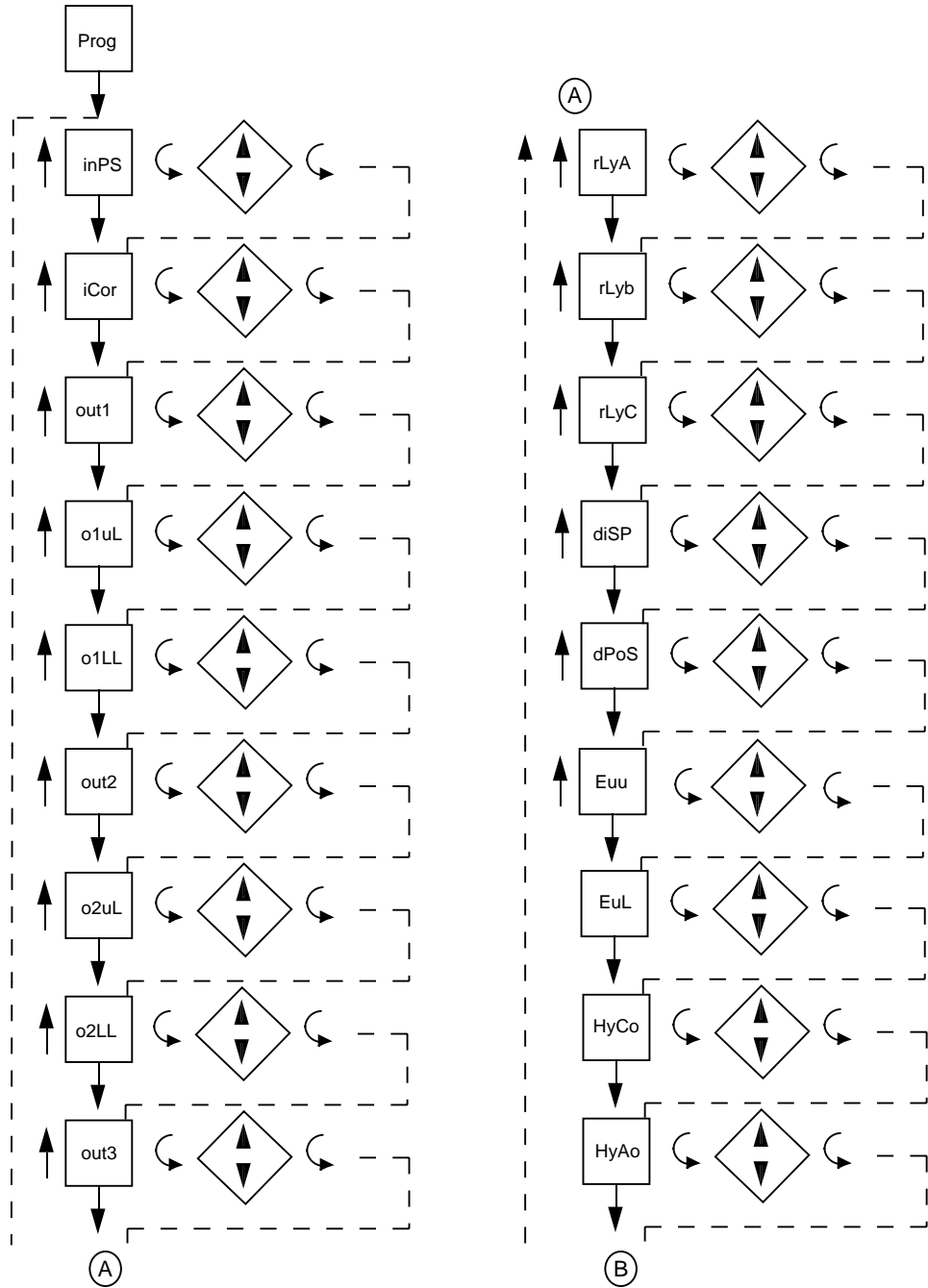

Key

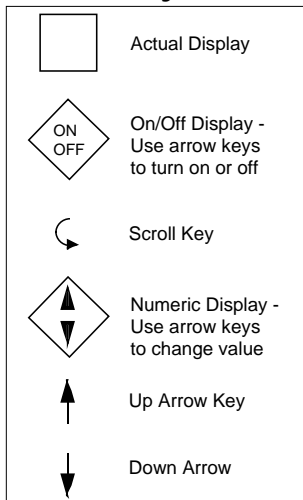

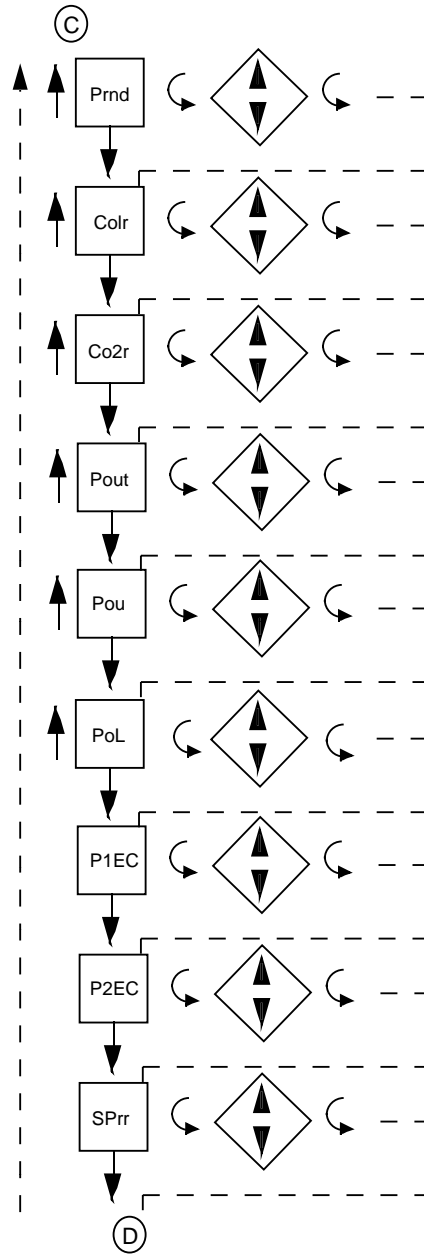
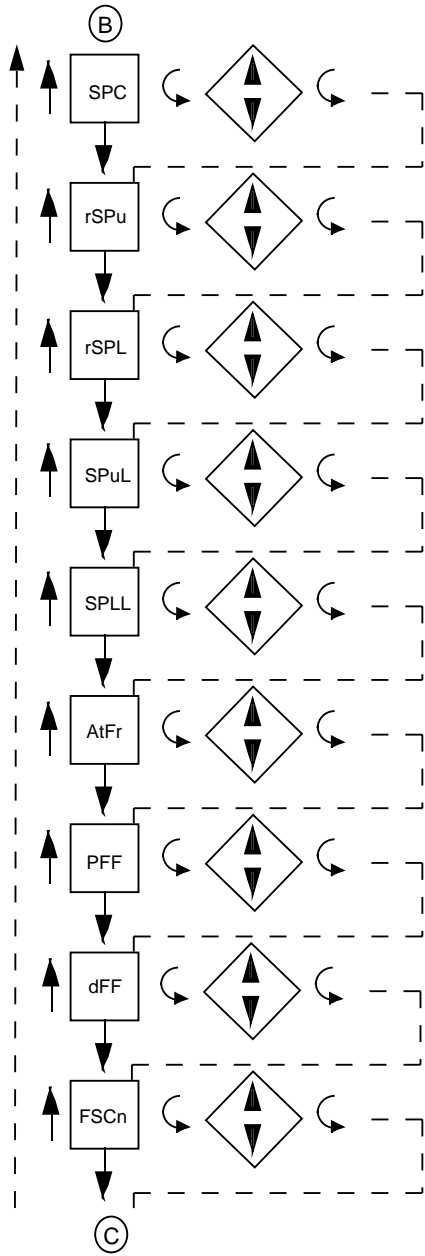

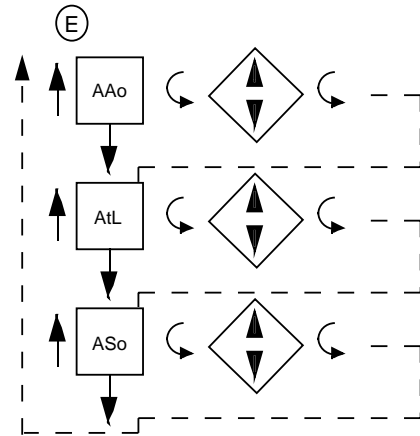
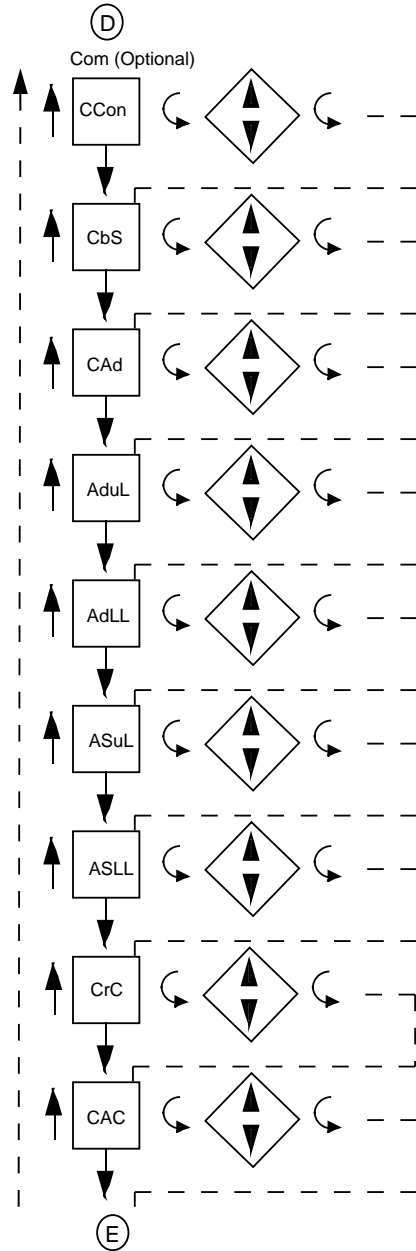

Key

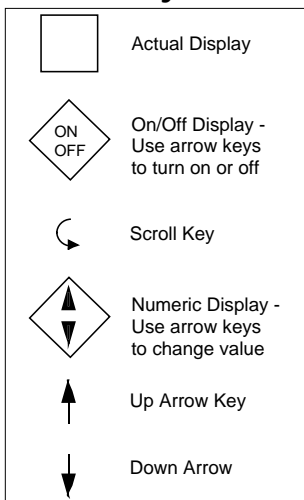

TABLE 3-2 PROGRAM MODE CONFIGURATION PROCEDURE

Press and release the SCROLL key until **Prog** is displayed. Use the DOWN key to enter the Program mode. Depress and release the SCROLL key to advance the display through the parameters and their values. The upper display will show the parameter codes. The lower display will show the parameter value selected. Use the UP and DOWN keys to adjust the parameter values. After adjusting a parameter, depress the SCROLL key to proceed to the next parameter. After all selections have been made, depress the UP key with a parameter code in the upper display and the lower display blank to exit the mode.

Note that parameter values are referred to in Degrees (°) and Engineering Units in the following tables. The input selection determines what the parameter values will be.

STEP	DESCRIPTION	DISPLAY CODE	AVAILABLE SETTINGS	FACTORY YOUR SETTING SETTING
1	Input Select	inPS	0 = J °C Thermocouple 1 = J °F 2 = K °C 3 = K °F 4 = T °C 5 = T °F 6 = R °C 7 = R °F 8 = S °C 9 = S °F 10 = E °C 11 = E °F 12 = B °C 13 = B °F 14 = N °C 15 = N °F 16 = C °C 17 = C °F 20 = RTD °C 21 = RTD °F 30 = 0 - 5VDC / 0 to 20mA 31 = 1 - 5VDC / 4 to 20mA 32 = 0 - 50mVDC 33 = 10 - 50mVDC 34 = 0 - 25mVDC	1
2	Input Correction	iCor	-300° to 300°/Units	0
3	Output 1	out1	1 = On-Off Direct (Cooling) 2 = On-Off Reverse (Heating) 3 = Time Proportioning - Direct (Cooling) 4 = Time Proportioning - Reverse (Heating) 5 = Current Proportioning - Direct (Cooling) 6 = Current proportioning - Reverse (Heating) 7 = Position Proportioning - Open	2
4	Output 1 % Upper Limit (o1uL and o1LL will be displayed if out1 is not selected as 1 or 2)	o1uL	1 to 100%	100
5	Output 1 % Lower Limit	o1LL	0 to 100%	0

STEP	DESCRIPTION	DISPLAY CODE	AVAILABLE SETTINGS	FACTORY YOUR SETTING	SETTING
6	Output 2	out2	0 = None or Position Proportioning Direct -Close 1 = On-Off Direct (Cooling) 2 = On-Off Reverse (Heating) 3 = Time Proportioning-Direct (Cooling) 4 = Time Proportioning-Reverse (Heating) 5 = Current Proportioning-Direct (Cooling) 6 = Current Proportioning-Reverse (Heating) 7 = Position Proportioning Reverse -Close	0	
7	Output 2 % Upper Limit (o2uL and o2LL will be displayed if out2 is selected as 3,4,5,6)	o2uL	1 to 100%	100	
8	Output 2 % Lower Limit	o2LL	0 to 100%	0	
9	Output 3	out3	0 = None 1 = Process Alarm-Direct 2 = Process Alarm-Reverse 3 = Deviation Alarm-Direct 4 = Deviation Alarm-Reverse 5 = Deviation Band Alarm-Open within band 6 = Deviation Band Alarm-Closed within band	0	
10	Relay A Assignment	rLyA	0 = Not assigned 1 = Assigned to Output 1 2 = Assigned to Output 2 3 = Assigned to Output 3	1	
11	Relay B Assignment (rLyb will be displayed if the relay is specified at the time of order)	rLyb	Same selection as Relay A	2	
12	Relay C Assignment (rLyC will be displayed if the relay is specified at the time of order)	rLyC	Same selection as Relay A	3	
13	Upper Display Select	diSP	1 = Process Value (PV) 2 = Deviation	1	
14	Decimal Position	dPoS	0 or 1 for T/C and RTD Input 0 to 3 for volt/mV Input	0	
15	Engineering units Upper Value (Euu and EuL will be displayed if inPS = 30, 31, 32, 33, 34)	Euu	-9999 to 9999	1000	

STEP	DESCRIPTION	DISPLAY CODE	AVAILABLE SETTINGS	FACTORY SETTING	YOUR SETTING
16	Engineering units Lower Value	EuL	-9999 to 9999	0	
17	Hysteresis for On/Off Control Output(s)	HyCo	0 to 300°/Units (width of hysteresis band)	3	
18	Hysteresis for Alarm Output	HyAo	0 to 300 °/Units (width of hysteresis band)	3	
19	Setpoint Configuration	SPC	0 to 4 0 = Single Local Setpoint **1 = 1 to 5VDC Remote Setpoint and Single Local Setpoint **2 = 0 to 5VDC Remote Setpoint and Single Local Setpoint 3 = Dual Local Setpoint - keypad selectable **4 = Dual Local Setpoint - Remote Dry Contact Closure Selectable	0	
<p>**These features can be selected in the setpoint configuration but will not function unless the Remote Setpoint option is present, model #82XXX2X.</p>					
20	Remote Setpoint Upper Limit (rSPu and rSPL will be displayed if SPC is selected as 1 or 2 and model #82XXX2X has been selected)	rSPu†	-9999° to 9999°/Units	1400*	
21	Remote Setpoint Lower Limit	rSPL†	-9999° to 9999°/Units	0*	
22	Setpoint Upper Limit	SPuL#	-9999° to 9999°/Units	1400*	
23	Setpoint Lower Limit	SPLL#	-9999° to 9999°/Units	0	
24	Automatic Transfer	AtFr	0 = No automatic transfer 1 = Transfer when PV goes below setpoint 2 = Transfer when PV goes above setpoint	0	
25	Process Filter Factor	PFF	1 to 20 (# of scans averaged) 1 = no filtering	1	
26	Display Filter Factor	dFF	1 to 20 (# of scans averaged) 1 = No Filtering	1	
27	Fast Scan	FSCn	0 or 1 0 = Standard Scan - 1 per second 1 = Fast Scan - 3 per second	0	† Sets scale of remote signal. # Both Local & Remote Limits

STEP	DESCRIPTION	DISPLAY CODE	AVAILABLE SETTINGS	FACTORY SETTING	YOUR SETTING
28	Process Rounding	Prnd	1 to 100 degrees/units 1 = no rounding	1	
29	Current Output 1 Range	Co1r	0 = 0 to 20mADC 1 = 4 to 20mADC	1	
30	Current Output 2 Range	Co2r	0 = 0 to 20mADC 1 = 4 to 20mADC	1	
31	Process Output	Pout	0 = Not selected 1 = Assigned to Current Output 1 2 = Assigned to Current Output 2	0	
32	Process Output Upper Value (Pou and PoL will not be seen if Pout=0)	Pou	-9999 to 9999 degrees/units	2000	
33	Process Output Lower Value	PoL	-9999 to 9999 degrees/units	0	
34	Proportional Output 1 Action on Error Condition (P1EC will not be seen if out1=1,2)	P1EC	0 - 100%	0	
35	Proportional Output 2 Action on Error Condition (P2EC will not be seen if out2=0,1,2,7)	P2EC	0 - 100%	0	
36	Setpoint Ramp Rate (Cannot be used in conjunction with Auto Tune)	SPrr	0 to 100°/Units per minute 0 = not used	0.0	

Communication Parameters 37-39 are optional and will only be displayed on models 82XXX3X, 82XXX4X, 82XXX5X or 82XXX6X

37	Communications Configuration	CCon	0 = Off 1 = Monitor (Read Only) 2 = Full Communications (Read & Write)	0, 4*	
38	Communications Bit Rate	CbS	1 = 300 bit rate 2 = 600 bit rate 3 = 1200 bit rate 4 = 2400 bit rate 5 = 4800 bit rate 6 = 9600 bit rate	6	
39	Communications Address	CAd	0 to 99	0, 1*	

* Factory setting for Total Access

STEP	DESCRIPTION	DISPLAY CODE	AVAILABLE SETTINGS	FACTORY SETTING	YOUR SETTING
40	Auto Tune Deviation Upper Limit	AduL	0° to 1000°	0	
40	Auto Tune Deviation Lower Limit	AdLL	0 to 5000° 0 = no lower limit	0	
40	Auto Tune Setpoint Upper Limit	ASuL	-9999° to 9999°	1400*	
41	Auto Tune Setpoint Lower Limit	ASLL	-9999° to 9999°	0	
42	Control Response Criteria	CrC	1.0 to 2.0 1.0 = 1/4 Amplitude Decay Response 2.0 = Damped Response	2.0	
43	Control Algorithm	CAC	1 = PID 2 = PI 3 = P	2	
44	Auto Tune Abort Option	AAo	0 = Go into Standby at 0% output 1 = Go into Standby at o1LL % output 2 = Go into Control with last PID parameters 3 = Go into control with PID parameters of ArS1 = 0, rt1 = 0 and a) if dPoS = 0, Pb1 = 100 b) if dPoS = 1, Pb1 = 10	0	
45	Auto Tune Time Limit	AtL	0 = No Limit 1 to 500 minutes	0	
46	Auto Tune Select Option for On Demand	ASo	0 = On demand not selected 1 = On demand selected	0	

* Whenever inPS is changed, the parameter is set to the upper limit of advertised span as indicated in the specifications section (Appendix D, page 74)

TUNEMODEFLOWCHART

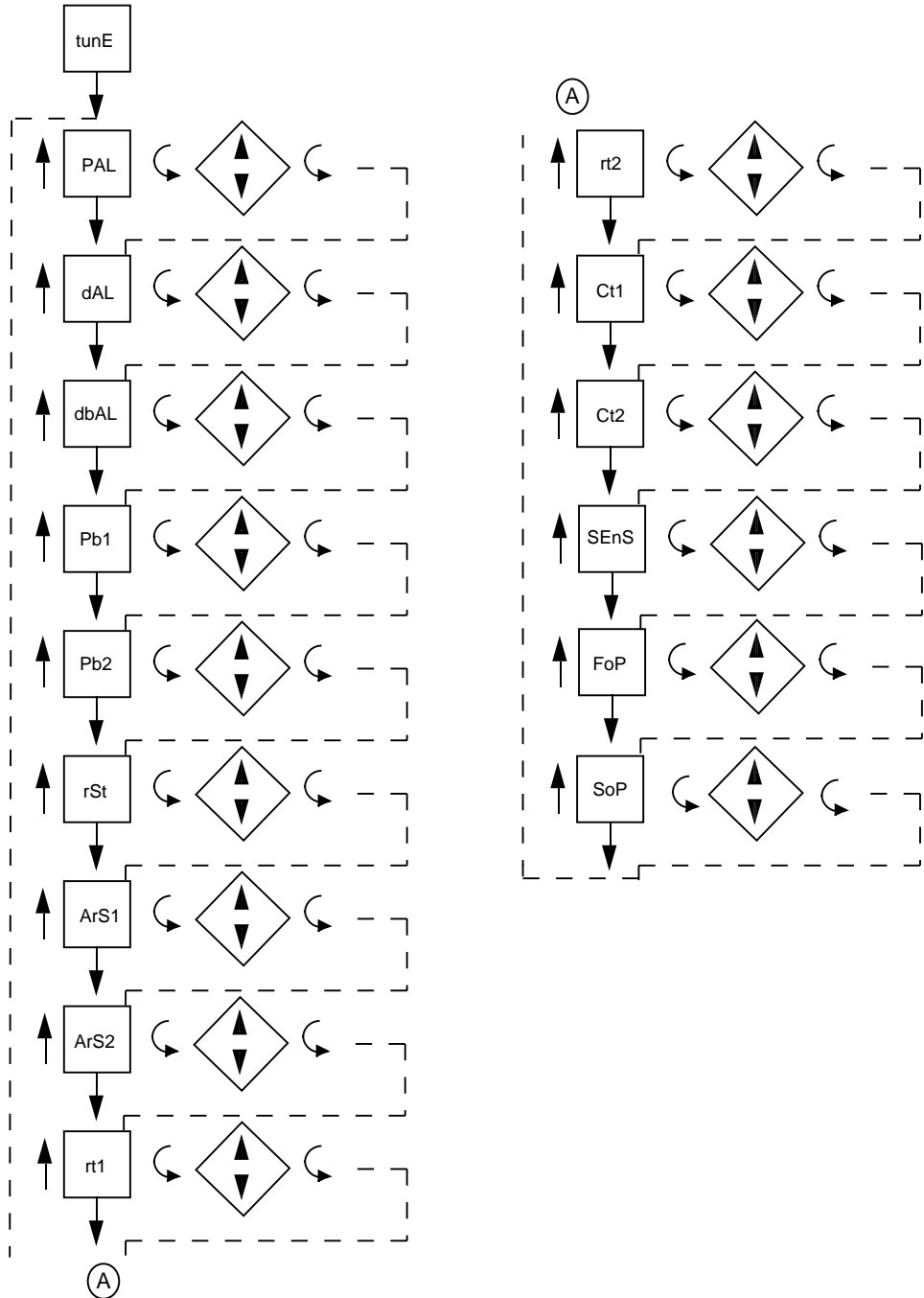

Key

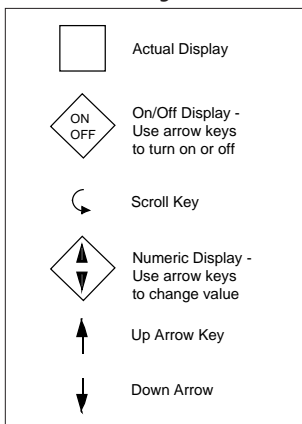

TABLE 3-3 TUNE MODE CONFIGURATION PROCEDURE

Depress and release the SCROLL key until **tunE** is displayed. Use the DOWN key to enter the Tune mode. Depress and release the SCROLL key to sequence through the parameters and their values. The upper display will be the parameter code, the lower display will indicate the parameter value selected. Use the UP and DOWN keys to adjust the values. After adjusting a parameter, depress the SCROLL key to proceed to the next parameter. Use the DOWN key to advance to the next parameter code when a parameter code is showing in the upper display and the lower display is blank. After all selections have been made, depress the UP key with a parameter code showing in the upper display and the lower display blank, to exit the mode.

STEP	DESCRIPTION	DISPLAY CODE	AVAILABLE SETTINGS	FACTORY SETTING	YOUR SETTING
1	Process Alarm (PAL will be seen if out3 =1 or 2)	PAL	-9999 to 9999 °/units	0	
2	Deviation Alarm (dAL will be seen if out3 =3 or 4)	dAL	-3000 to 3000 °/units	0	
3	Deviation Band Alarm (dbAL will be seen if out3 =5 or 6)	dbAL	1 to 3000°/units	1	
4	1st Output Proportional Band Width (Pb1 will not be seen if out1 =1,2)	Pb1	1 to 3000°/units	100	
5	2nd Output Proportional Band Width (Pb2 will not be seen if out2 =0,1,2,7)	Pb2	1 to 3000°/units	100	
6	Manual Reset	rSt	-1500 to 1500°/units	0	
7	Automatic Reset Output 1 (Integral)	ArS1	0.0 to 100.0 repeats per minute	0.0	
8	Automatic Reset Output 2 (Derivative)	ArS2*	0.0 to 100.0 repeats per mintue	0.0	
9	Rate (Derivative) Output 1	rt1	0.0 to 10.0 minutes	0.0	
10	Rate (Derivative)	rt2*	0.0 to 10.0 minutes	0.0	
11	Cycle Time Output 1 (Ct1 will be seen if out1 =3,4,7)	Ct1	1 to 240 seconds	30	
12	Cycle Time Output 2 (Ct2 will be seen if out2 =3 or 4)	Ct2	1 to 240 seconds	30	

(Continued on next page)

(Continued from page 35)

STEP	DESCRIPTION	DISPLAY CODE	AVAILABLE SETTINGS	FACTORY SETTING	YOUR SETTING
13	Position Prop. Sensitivity (SEnS will be seen if out1=7 and out2=0 or 7)	SEnS	0.0 to 50.0%	1.0	
14	First Output Position	FoP	-1000 to 1000°/units	0	
15	Second Output Position (SoP will not be seen if out2=0)	SoP	-1000 to 1000°/units	0	

* **ArS2** and **rt2** are not used by the Control algorithm if both Output 1 and Output 2 are selected for the same proportional control (reverse or direct). The parameters are used when one output is selected for direct and the other is selected as reverse.

Note: The Program, Tune and Enable Mode selections can be conveniently recorded on the Software Reference Sheet located in Appendix E (page 76).

Auto Tune Method 3.4

The Auto Tune function will select the tuning parameters for a proportional control heating application assigned to Output 1. For the Auto Tune to properly calculate the Tune mode parameters, the Program and Tune mode parameters listed below must be correctly selected.

3.4.1 PROGRAM MODE PARAMETERS THAT AFFECT AUTOTUNING

- Output 1 **out1** must be set for proportioning reverse (heating) (4, 6, 7) output action.
- Output 1 upper limit **o1uL** can be used to limit the maximum heating output percentage. This will affect the process response curve used to calculate the tuning parameters. If overshooting or Er56 occurs, reducing the maximum output percentage may be necessary.
- Output 1 lower limit **o1LL** can be used to select a minimum output value. The instrument can be directed to output this minimum value if the Auto Tune aborts (fails) by use of the Auto Tune Abort **AAo** option.
- Output 2 **out2** can not be selected as time or current proportioning reverse (4 or 6). If **out1 = 7**, then **out2** must be 7. **Out2** may be used for direct cooling action.
- Auto Tune can only be initiated when Setpoint Configuration **SPC** is 0, 1, 2, or 3 and **SP1** is active. In other words, when **SP2** or remote setpoint is active, Auto Tune can not be initiated and the AUTO TUNE key is ignored. If **SPC** is 4, Auto Tune can not be initiated.
- The Auto Tune will not function if the Setpoint Ramp Rate is selected other than 0.0.

7. The Auto Tune Deviation upper limit **AduL** serves 2 functions: (which depend upon the Auto Tune Select option parameter selected, see step 46 on page 33).
- A. If the Auto Tune Select option **ASo** = 0, then the process value (temperature) must be less than the setpoint value minus the **AduL** value in order for the Auto Tune to function. Auto Tune will not function if the $PV > SP - AduL$.
Example: if $PV = 200$, $SP = 230$ and **AduL** = 50, the Auto Tune will not function (see Appendix B, page 68).
 - B. If **ASo** = 1 and the process value is greater than the setpoint value minus **AduL**, the heating **out1** control output will be turned off when the AUTO TUNE key is pressed. When the process value drops below the setpoint value minus the **AduL** value, the heating control output will be turned on so the Auto Tune function can begin (see Appendix B, page 68).
- Note: In order for **AduL** to have an effect on Auto Tune, the **AduL** value must be greater than 20 degrees or 5 % of the setpoint value, whichever is greater, initiating the Auto Tune function.
8. Auto Tune Deviation lower limit **AdLL**:
- A. If **AdLL** = 0 when the Auto Tune key is pressed the Auto Tune process response calculations will begin when the process value reaches the point 1/2 way between the setpoint value and the process value at the time when the AUTO TUNE key was pressed. Example: If $SP = 1200$ and $PV = 400$, then the response calculations will be considered when the $PV > 800$.
 - B. If **AdLL** > 0, when the Auto Tune key is pressed, the Auto Tune process response calculations will begin when the process value rises above the point that is the result of subtracting 1/2 of the **AdLL** value from the setpoint value.
9. Auto Tune setpoint upper limit **ASuL** sets a maximum setpoint limit over which the auto tune will not initiate. Typically selected at application maximum setpoint value plus 10%.
10. Auto Tune setpoint lower limit **ASLL** sets a minimum setpoint limit under which the Auto Tune will not work. **ASLL** must be lower than **ASuL** (see Appendix B, page 68)
11. The Control Response Criteria **CrC** is used to select the desired type of control response for the process. Selecting 1.0 will provide good response to system upsets but may allow overshooting of the setpoint. Selecting a value of 2.0 may result in a slow response to system upsets but provide a stable process control. Selecting values between 1.0 and 2.0 will result in process control somewhere between the two extremes described. Actual process response will depend upon the application.
12. Control algorithm choice **CAC** allows selection of the type of control that best suits the process. For example, if the process acts a little unstable after Auto Tuning with PID selected, changing to the **CAC** PI and re-Auto Tuning may improve process stability.
13. Auto Tune abort option **AAo** is used to select what the controller will do if the Auto Tune function can not complete. Select the **AAo** parameter code that is best for your application.
14. Auto Tune time limit **AtL** selects a time limit that will cause the Auto Tune to abort if the process response calculations have not been completed. Start at 0, no time limit, if unfamiliar with the process reaction time needed.
15. The Auto Tune on demand **ASo** parameter, if selected as 0, will disable the Auto Tune function when the process variable is within the **AduL** value below setpoint. If **ASo** is selected as 1, the Auto Tune will work when the process variable is within the **AduL** value below setpoint as described in number 6 previously (page 37).

3.4.2 TUNEMODE

1. Manual Reset **rSt** should be set to 0 when performing the initial Auto Tune. This parameter may be adjusted later, if desired.
2. Cycle Time for Output 1 **Ct1** may need to be adjusted when using time proportioning control. Typically the lowest cycle time settings result in the smoothest process control. However, low cycle time will reduce the life of mechanical relays. For motor modulation control, the cycle time setting must be the stroke time of the motor. Adjusting the cycle time affects the instrument operation. Shorter cycle time causes more accurate control and shorter life span of electro-mechanical components. Longer cycle time causes less control accuracy and longer life span of electro-mechanical components.
3. First Output Position deviation from setpoint **FoP** should be set to 0 when performing the initial Auto Tune. This may be adjusted later, if desired .
4. Second Output Position deviation from setpoint **SoP**, depending upon the application, may affect the process control response curve that is used by the Auto Tune calculations. Set **SoP** to 0 when performing Auto Tune.

3.4.3 AUTOTUNEOPERATION

1. Select the Program and Tune mode parameters as necessary for the application as described in this section.
2. Use the UP or DOWN key to select the setpoint 1 value for the application.
3. Press the AUTO TUNE key.
4. The lower display will show **Atun** to indicate that the Auto Tune function is operating. When the Auto Tune function is complete, **Atun** will not be displayed.
5. Observe the process response, if any error codes appear, consult the Trouble-shooting Section for the appropriate response (page 56).
6. If you wish to abort (stop) the Auto Tune, press the AUTO TUNE key once more. This will cause **Er58** to be displayed and the controller will operate as selected by the **AAo** parameter.
7. For optimum control, some applications may require manual adjustments of the Tune mode parameters.
8. When the Auto Tune function has completed and the process control is satisfactory, you may wish to disable the Auto Tune function and the Tune mode to prevent inadvertant changes to the tuning parameters.

Manual Tuning Method 3.5

1. Cycle Time - Time Proportioning Outputs
 - A. Adjusting the cycle time affects instrument operation
 1. Shorter Cycle Time
 - a. More accurate control
 - b. Shorter life span of electro-mechanical components
 2. Longer Cycle Time
 - a. Less control accuracy
 - b. Longer life span of electro-mechanical components
2. Proportional Bandwidth
 - A. Proportional Bandwidth is the inverse of gain.
Increased Bandwidth = Decreased Gain
 - B. Increase the Proportional Bandwidth if:
 1. The process overshoots excessively.
 2. The process oscillates excessively.
 - C. Decrease the Proportional Bandwidth if:
 1. The process responds slowly
 2. The process fails to reach setpoint
3. Add Automatic Reset
 - A. Increase the Automatic Reset in steps of .2 repeats per minute until the process becomes unstable, then decrease until stability is restored.
 - B. Be sure to allow sufficient time for the process and the instrument to react.
4. Rate Adjustment
 - A. Rate can cause process instability. Typically add Rate as 1/10th of the automatic reset value.
 - B. Decrease Rate if:
 1. The process overshoots/undershoots
 2. If the process oscillates excessively
5. Manual Reset
 - A. After making all other adjustments, use if an offset exists between the setpoint and the process variable.
 - B. If the process is:
 1. Below setpoint use a positive Manual Reset value equal to the difference.
 2. Above the setpoint use a negative Manual Reset value equal to the difference.

Control Capability 4.1

A variety of user programmable control features and capabilities are available including:

- AutoTune
- Time Proportioning Control
- Position Proportioning Control
- Dual Output Control
- Automatic Transfer
- Process Re-transmission
- On-Off Control
- Current Proportioning
- Alarm Functions
- Auto/Manual Switching
- Setpoint Adjustment

The capabilities available in a specific unit are dependent upon the hardware options specified when the instrument is ordered. Refer to Appendix C (page 58) for the decoding of the instrument model number. Current proportioning control cannot be implemented if a current output was not ordered. Position proportioning cannot be implemented if two relays (Outputs 1 and 2) and the option have not been ordered. The available output types and quantity of each are as follows:

Type of Output	Quantity Available
* SPST mechanical relay output	Up to three
* SSR Driver	Up to three
* mADC current output	Up to two

The maximum number of SPST relay and/or SSR driver outputs available on a single instrument is three. Relay and SSR drivers may be assigned as either control or alarm outputs. The mADC current output(s) may be assigned control or process value retransmission output functions.

Control Responses 4.2

Each instrument may be configured to provide 3 mode proportional control. Proportional control is provided with Proportional Band, Integration, and Derivative responses. The PID parameters are defined as follows:

		Out 1	Out 2
P (Proportional)	Proportional Band	Pb1	Pb2
I (Integration)	Automatic Reset	ArS1	ArS2
D (Derivative)	Rate	rt1	rt2

Manual Reset is provided for use in lieu of, or in conjunction with automatic reset. A cycle time adjustment parameter is provided for use with each time proportioning control output.

Direct/Reverse Operation of Outputs 4.3

Direct operation is typically used with cooling applications. On-Off direct output(s) will turn on when the process variable exceeds setpoint. Proportional direct output(s) will increase the percentage of output as the process value increases within the proportional band.

Reverse operation is typically used with heating applications. On-Off reverse output(s) will turn off when the process variable exceeds setpoint. Proportional reverse output(s) will decrease the percentage of output as the process value increases within the proportional band.

On-Off Control 4.4

On-Off control can be implemented with SPST relay or SSR driver output(s). On-Off operation can be assigned to either or both Output 1 and 2. A hysteresis adjustment is provided for On-Off Outputs. This adjustment is in terms of degrees/engineering units and defines the bandwidth of the hysteresis. The hysteresis value straddles the setpoint. Relay chatter can be eliminated by proper adjustment of this parameter. When operating in On-Off control, the output(s) will turn on or off depending upon the setpoint, the process value, Tune mode selections, and the hysteresis adjustment.

Time Proportioning Control 4.5

Time Proportioning control can be implemented with a SPST relay or SSR driver. Time Proportioning control can be selected for either Output 1 and/or Output 2, depending on hardware configuration. Time Proportioning control is accomplished by cycling the output on and off during a prescribed period of time when the process variable is within the proportional band.

Ex: Calculated output % = 40%; Cycle time adjustment = 20 seconds
Output on time = $.4 \times 20 = 8$ seconds
Output off time = $.6 \times 20 = 12$ seconds

When the unit is operating in the Control mode, the control algorithm determines the output % required to correct for any difference between the process value and the setpoint. The output calculation is affected by Tune mode parameter adjustments.

See Figure 4-1 (page 42) for proportional bandwidth effect on the output.

Current Proportioning Control 4.6

Current Proportioning control can be implemented on units provided with mA DC current output(s). Current Proportioning control provides a 4 to 20mA DC or 0 to 20mA DC output in response to process value and setpoint. As with Time proportioning, the calculated output % for Current proportioning control is affected by the Tune mode parameter adjustments.

See Figure 4-1 (page 42) for proportional bandwidth effect on the output.

Position Proportioning Control 4.7

Position Proportioning Control can be implemented on those units provided with two SPST relay or two SSR driver outputs and the Position Proportioning (slidewire feedback) option.

Position Proportioning control permits the use of PID control when the final control element is a modulating device such as a motorized valve. Two outputs are required to control the valve. One output opens the valve, the second output closes the valve. The slidewire feedback is used to indicate the valve position to the instrument. The valve position will be dependent upon the process value, the setpoint and Tune mode parameters. (Continued on next page)

(Continued from page 41)

A Position Proportioning sensitivity adjustment is provided, which specifies a deadband around the setpoint to prevent the valve from oscillating. The valve rotation time must be entered, for proper operation, into the Tune mode parameter **Ct1**.

See Figure 4-1 for proportional bandwidth effect on the output.

FIGURE4-1

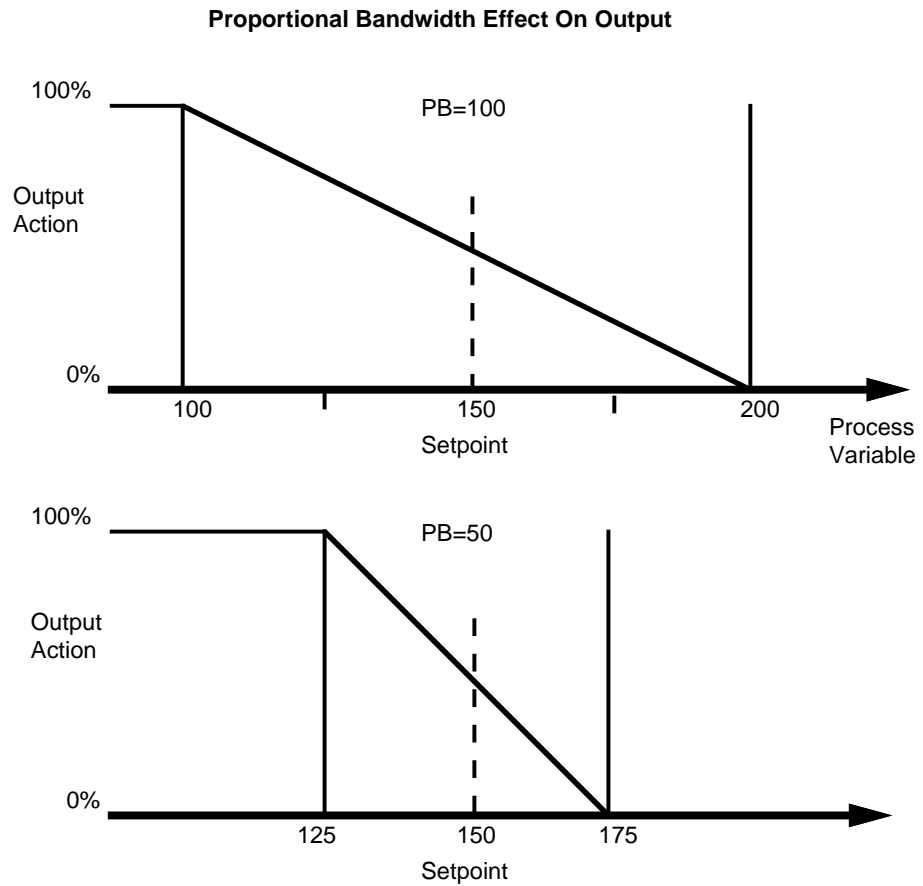

The Proportional Bandwidth is the area where the output is a percentage of the full output. The size of the proportional band determines what change in the output will result from a change in the process variable. In the upper figure when the process variable is at 125 the output will be at 75% of full output. In the lower figure the proportional bandwidth is smaller. When the process variable is at 125 the output is now at 100%. The larger the proportional band the smaller the "gain" and vice versa.

Dual Output Control 4.8

Dual output control can be performed when two outputs are specified. The outputs may be programmed for On-Off, Time Proportioning, or Current Proportioning, as applicable. To utilize the Auto Tune feature, Output 1 must be programmed for proportional reverse action.

The output action is dependent upon the setpoint, the process value, and Tune mode parameters. If two proportional outputs are selected, both output proportional bands will be biased so that 0 % of output is seen when the process value equals setpoint. The output(s) can be biased by the use of the Tune mode parameters **FoP** and **SoP** as shown below.

FIGURE4-2

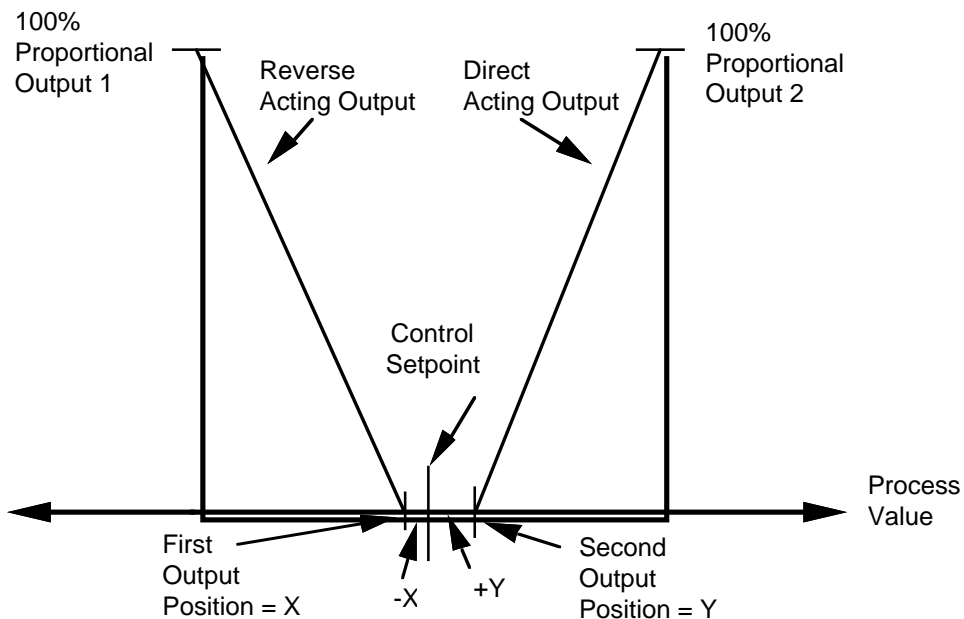

The first output is programmed as a proportional reverse output and the second as a proportional direct output. (See Glossary, page 68, for definitions of these terms). Dual proportioning outputs are provided with separate proportional band; auto reset, rate, and cycle time adjustments for each output.

Manual Operation of Proportional Outputs 4.9

To enter the Manual mode, press and release the AUTO/MANUAL key. If the Standby mode is on in the Enable mode the instrument will enter the Manual mode. The Manual mode status LED will light to indicate that the Manual mode is in use. Shifting from the Control to the Manual mode is bumpless. The proportional output(s) will stay at the last value(s) calculated by the control algorithm. The upper display will show the current process value. If Output 1 is a proportional output, the lower display will show the Output 1 percentage of output value and the PO1 status lamp will light. If PO1 is not a proportional output, the lower display will show the Output 2 percentage of output and the PO2 status lamp will light. If dual proportional outputs have been selected, press the SCROLL key to toggle the lower display between the PO1 and the PO2 values. To change the percentage of output value, press the SCROLL key to display the percentage output value that you desire to adjust. Use the UP or DOWN key to change the percentage value as desired.

To exit the Manual mode of operation press the AUTO/MANUAL key once more. The Manual mode status LED will go out. The Auto Transfer to the Control mode function can be selected in the Program mode to shift the instrument from Manual to Control mode automatically when the process variable reaches setpoint.

The proportional control output value(s) may change rapidly when returning to the Control mode. The output change will depend upon the Tune mode selections and the process value deviation from setpoint at the time of transfer.

Automatic Transfer Function 4.10

Automatic transfer provides automatic shifting from the Manual mode to the Control mode of operation when the process value reaches setpoint. This feature is selectable in the Program mode.

SETPOINTSELECTFLOW/CHART

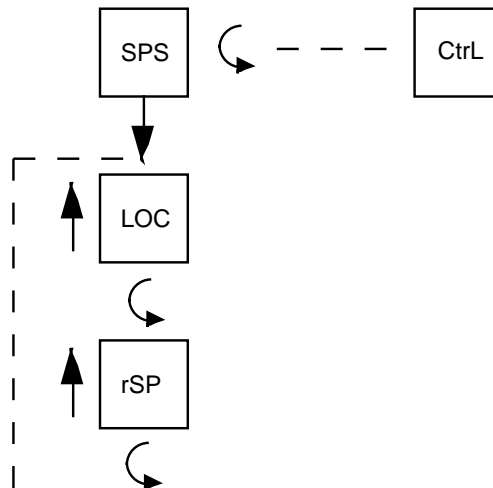
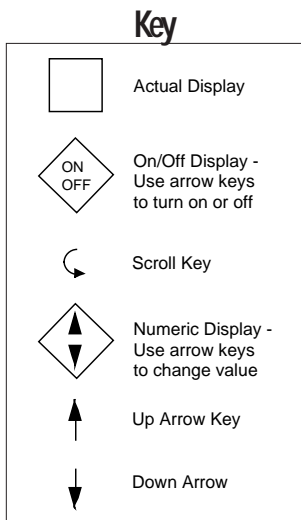

Setpoint Adjustments 4.11

Local Single Setpoint

Local single setpoint adjustment, if selected in the Program mode, is accomplished by using the keypad. Press the UP key to increase the setpoint value. Press the DOWN key to decrease the setpoint value. Holding the key pressed will cause the value to change slowly at first then increasingly faster. The range of setpoint values can be limited by selecting the desired setpoint upper limit **SPuL** and the setpoint lower limit **SPLL** values in the Program mode. The setpoint value can be protected from inadvertent changes by disabling the Setpoint Change, **ESPC**, in the Enable mode.

Local Dual Setpoint

Local dual setpoint adjustment, if selected in the Program mode, is accomplished by using the keypad. Press the SP1/SP2 key to select either **SP1** or **SP2**. Press the UP key to increase the setpoint value displayed. Press the DOWN key to decrease the setpoint value displayed. Press the SP1/SP2 key to display the alternate setpoint value. Use the UP or DOWN key(s) as necessary to adjust the alternate setpoint value. The range of setpoint values can be restricted by selecting the setpoint upper limit **SPuL** and the setpoint lower limit **SPLL** values in the Program mode. Press the SP1/SP2 key to toggle the setpoint value from **SP1** to **SP2** and visa versa. The Auto Tune will function at the Setpoint 1 value. If the second setpoint is active when the AUTO TUNE key is pressed, the key will be ignored.

Ramp Rate

A selectable Ramp Rate function can be used to limit the rate at which the setpoint used by the control algorithm will change. This feature will also establish a soft startup. Upon power up, the instrument will take the initial process value as the setpoint. A setpoint ramp rate will be calculated to increase the setpoint from the initial process value to the setpoint selected. The setpoint ramp rate feature cannot be used with the Auto Tune function.

Sudden changes in the setpoint value entered via the keypad can be inhibited from affecting the control outputs by use of this feature. The internal setpoint used to control the process will ramp to the setpoint value entered at the rate of change selected.

Note: The displayed SP is not the same as the ramp SP.

FIGURE 4-3

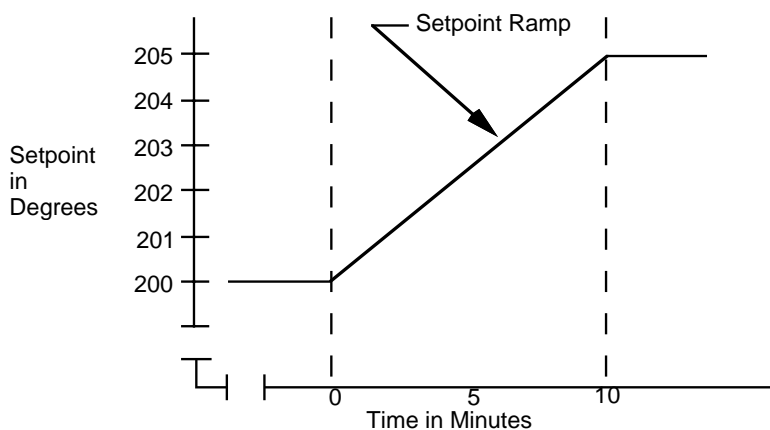

Remote Setpoint (Optional)

The instrument setpoint can be adjusted by supplying a signal to the remote setpoint terminals as indicated in the installation section. Local or Remote setpoint operation is selected by pressing and releasing the SCROLL key until the upper display reads setpoint select **SPS**. Press the DOWN key to enter the Setpoint Select mode. The lower display will change to show the current setpoint mode, either local **loc** or remote **rSP**. To change the setpoint mode press the SCROLL key. To exit the setpoint mode press the UP key. To prevent unwanted setpoint mode changes, the Setpoint Select mode can be disabled in the Enable mode, **ESPS**. When remote setpoint is active, the AUTO TUNE key is ignored.

Remote Selection of Dual Local Setpoint (Optional)

To use this feature, a remote dry contact closure needs to be connected to the instrument between terminals 8 and 5 as shown in Section 2.2, page 11. In the Program mode, set the setpoint configuration value to 3 - Local Dual Setpoint. Exit the Program mode and follow the instructions for the Local Dual Setpoint to adjust the two setpoint values that are desired. Return to the Program mode and change the setpoint configuration parameter value from 3 to 4 - Remote Selection of Dual Local Setpoint. In this configuration, the AUTO TUNE key is ignored.

When a dry contact closure is sensed between terminals 8 and 5, the setpoint value will be the SP1 value. If no contact closure is sensed, the controller will be using the SP2 value.

The setpoint values can be adjusted by using the Digital Communications Option. Refer to the Protocol Manual (Form 2878) for more details about this option.

Process Re-transmission Output

If the instrument is provided with a current output not used for process control, this output may be assigned to provide a linear re-transmission of the process value. This output can be used to provide a process signal to remotely installed recorders, panel meters and data loggers. The process output is scaled for the application by using the Program mode parameters, process value upper **Pou** and process value lower **PoL**. The current output resolution is 200 steps, so for the best re-transmission accuracy the span between **Pou** and **PoL** should be as small as possible.

The example illustrated in Figure 4-4 shows a process re-transmission application for 0 to 200 degrees F.

FIGURE4-4

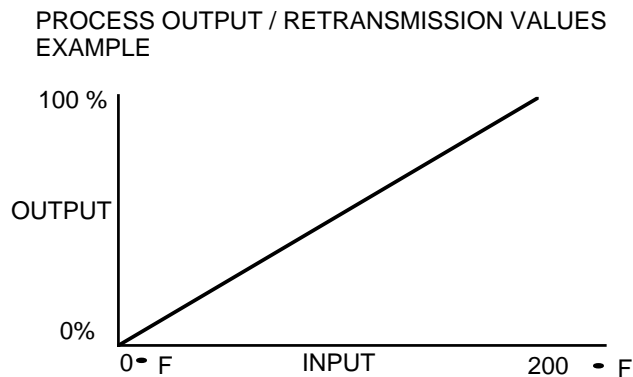

4.1.2 OUTPUT ACTION ON ERROR CONDITION

If the instrument displays a sensor problem code **Hi**, **Lo** or **Snsr** or any of the error codes 1-36, the On/Off Output(s) Control and Alarm will go off. The Proportional Control Outputs will go to a user selectable output % (P1EC, P2DC in the Program mode). The Process Re-transmission proportional output will go to 0%. Proportional control can be adjusted in the event of an error condition in the Manual mode. On/Off relays can be activated individually in the Test mode (Test 6).

Service 5.1

This section contains Calibration , Test and Trouble-shooting procedures that can be performed by the user. Instruments are calibrated to all input types at the factory prior to shipment. Re-calibration should not be necessary under normal operating conditions.

Calibration 5.2

Caution: Do not attempt any of these calibrations without the proper test equipment with specifications equal to or better than those listed.

Press and release the SCROLL key to sequence the upper display until **CAL** appears. If **CAL** does not appear refer to Section 3 for instructions on how to enable the Calibration mode. When **CAL** appears on the upper display, press the DOWN key. The display will read **CAL 1**. **CAL 1** can be initiated at this time or press the SCROLL key to advance the display to the other calibrations available. The lower display will remain blank in the Calibration mode.

TABLE 5-1 CALIBRATION PROCEDURES

<u>Calibration Procedure</u>	<u>Description</u>
CAL 1	Re-initialization of Program and Tune Mode values.
CAL 2	Main Calibration used by all inputs. This is the only calibration required for voltage and millivolt inputs.
CAL 3	Cold Junction Compensation calibration used to correct for component variation in CJC circuit.
CAL 4	Cold Junction utility. The temperature of the cold junction is displayed. No adjustment is made with this procedure.
CAL 5	RTD input calibration used to correct for component differences in the RTD input circuit.
CAL 6	CJC turn on/off
CAL 7	Factory Use Only

CALIBRATIONFLOWCHART

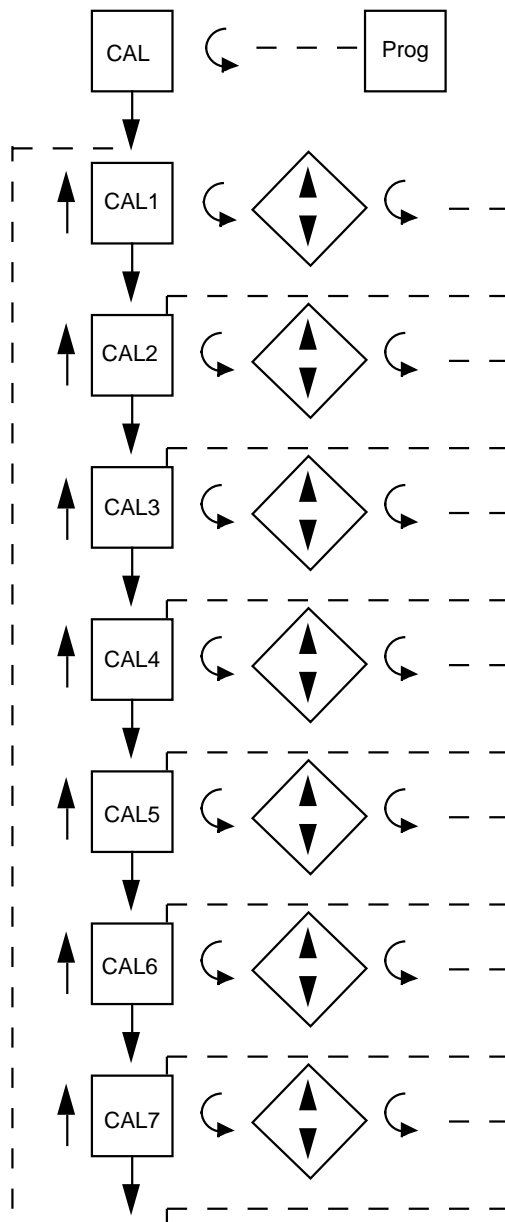

Key

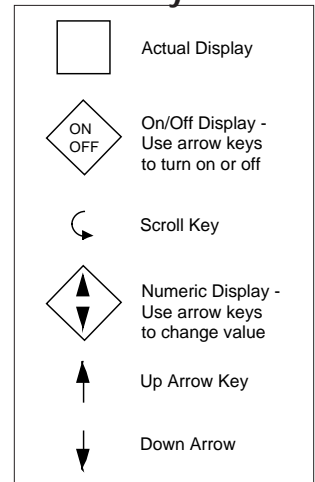

5.2.1 CAL1 PARAMETER INITIALIZATION

This procedure is performed to erase the information that was entered in the Program and Tune modes. All parameters will be reset to default values. Prior to beginning this procedure record the Program and Tune mode parameters so that they can be re-entered. No special test equipment is required.

With **CAL1** displayed, depress and hold the DOWN key, then press the SCROLL key. The display will momentarily go blank. Release the keys. **CAL1** will reappear on the display. This calibration can be done again or another may be selected.

5.2.2 CAL2 MAIN CALIBRATION

This procedure determines and saves calibration values which correct for component variations relating to the input measuring function of the instrument. **CAL2** is the only calibration required for the volt and millivolt inputs. Additional calibration procedures are required for thermocouple and RTD inputs.

A $50.00 \pm .01$ mVDC source is required for calibrating. In addition make sure that JU1 on the Processor board is in the "non volt" position. See Appendix A-2 (page 65).

With **CAL2** displayed, press and hold the DOWN key, then press the SCROLL key. Release both keys and the instrument will display **hLd1**. Short the input terminals 1 and 3 or apply $0.00 \pm$ mV to the input. Depress the DOWN key; **dELy** will appear for up to ten seconds, then **SCAn** will appear for up to ten seconds. A calibration reference number, which should be $0, \pm 50$, should then appear. With a number within tolerance display, connect a $50.00 \pm .01$ mV source to the input terminals. Press the DOWN key and **dELy** will be displayed for ten seconds and the **SCAn** for ten seconds. Then **CAL2** will reappear. If there is a problem, the appropriate error code will be displayed. Restore JU1 to the position necessary for the input type.

If the calibration reference number falls outside the $0, \pm 50$ tolerance, depress the SCROLL key and **CAL2** will be displayed. Depress the DOWN key and perform the calibration once more. Repeat the calibration until the number falls within the tolerance limits. If the calibration number remains outside these limits, check the connections to the test equipment and try the calibration again. If the number still does not approach the tolerance limits contact an Applications Service Engineer at the factory or a local representative.

Error Recovery - see 5.4 (page 56) for details. However, be sure that the millivolt source is securely connected, functioning properly and the polarity is correct. Press the DOWN key to bring the instrument back to **dELy** and try the calibration again. The calibration can be exited at anytime. **hLd1** or the reference number is displayed by pressing the SCROLL key.

CAL2 QUICK CALIBRATION

This routine will allow the operator to execute a rough calibration on their unit via the keypad with no other equipment or disturbance to established wiring. It is intended to provide a partial recovery from a calibration corruption where the necessary equipment indicated in CAL 2-5 may not be available. It should be noted that this is not intended as a substitution to the main calibration procedure described earlier and may considerably deter from the accuracy of the instrument.

With **CAL2** displayed, press and hold the DOWN ARROW key, then press the SCROLL key. Release both keys and the instrument will display **hLd1**. Press and hold the UP ARROW key, then press the SCROLL key. The display will momentarily blank and then **CAL1** will be displayed. Release both keys and depress the UP ARROW key. **CAL** will be displayed.

5.2.3 CAL3 COLD JUNCTION COMPENSATION

This procedure determines and saves calibration values which correct component variations relating to the cold junction compensation. This calibration must be preceded by **CAL2** the main calibration, to properly calibrate the instrument. These two calibrations are the only ones needed for proper operation with a thermocouple input.

For test equipment: one type J thermocouple and one mercury thermometer accurate to $\pm .25$ degrees C or equivalent is required. Allow 30 minutes of warm up time, with the thermocouple connected, before proceeding with calibration.

With **CAL3** displayed, depress and hold the DOWN key. Then press the SCROLL key and the unit will display **hoLd**. Release both keys. Connect the J thermocouple to the input terminals and place thermometer at the back of the unit. Press the DOWN key and **dELy** will

be displayed for ten seconds, then **SCAn** for ten seconds. The instrument will compute and display the cold junction temperature to the nearest tenth of a degree C. Compare reading with thermometer and use the UP and DOWN keys to correct the reading, if necessary. To end the procedure press the SCROLL key and **CAL3** will be displayed again.

The instrument may stay in **SCAn**. To establish a reasonable starting point, with **SCAn** displayed, press the SCROLL key. **CAL3** should be displayed. With **CAL3** displayed, while pressing the DOWN key, press the SCROLL key. The instrument will display **hOLd**. Press the UP key. The instrument will begin the calibration procedure with a default value and proceed to **deLy**. Complete calibration as described above.

Error Recovery - see 5.4 (page 56) for details on specific errors. The calibration can be exited at any time. **hOLd** is displayed by pressing the SCROLL key.

5.2.4 CAL4 COLD JUNCTION TEMPERATURE UTILITY

This procedure displays the temperature sensed by the cold junction compensator (CJC).

No special test equipment is required.

With **CAL4** displayed, press and hold the DOWN key then press the SCROLL key and release both keys. **SCAn** will be displayed for ten seconds while the instrument computes the CJC temperature. The result will then be displayed to a tenth of a degree C. The input terminals must be shorted with a jumper wire. Remember, the temperature displayed is that of the CJC terminals not the ambient temperature. To exit, press the SCROLL key and **CAL4** will be displayed.

5.2.5 CAL5 RTD INPUT

This procedure determines and saves calibration values which correct for component variations relating to RTD inputs. This calibration must be preceded by **CAL2** to properly calibrate the unit.

Test equipment needed will include a Decade Box (Resistance Substitution) with .01% resolution or equivalent. Make sure the jumpers JU1 (Processor Board), JU2 and JU3 (Options boards) are in the proper positions for RTD input. See Appendix A-2 (page 65) and A-3 (page 66 and 67).

With **CAL5** displayed press and hold the DOWN key, then press the SCROLL key and release both keys. **hLd1** will then be displayed. Connect the Decade Box at 100 ohm setting across the input terminals 1 and 3 and Jumper terminals 1 and 5. Press the DOWN key and **deLy** will be displayed for up to ten seconds, then **SCAn** for ten seconds. When **hLd2** is displayed, connect 277 ohms to the input and press the DOWN key. Again **deLy** will display for up to ten seconds, followed by **SCAn** for ten more seconds. **CAL5** will be displayed after the calibration is completed.

Error Recovery - See section 5.4 (page 56) for details about specific errors.

The Calibration mode can be exited any time the unit displays **hLd1** or **hLd2** by pressing the SCROLL key.

5.2.6 CAL6 COLD JUNCTION ON/OFF

With CAL 6 displayed, while pressing the DOWN ARROW key, press the SCROLL key. The instrument will display **C6** and the number of the mode in effect. Mode 0 is the normal operating mode. The cold junction compensation is on. Mode 1 is the cold junction compensation disabled (off). Pressing the UP ARROW or DOWN ARROW will change the mode selection. The Mode 1 functions to facilitate input testing with a non-temperature compensated millivolt source used to simulate thermocouple input.

Test Mode 5.3

The Test mode can be entered, if enabled, by pressing and releasing the SCROLL until **tEst** is displayed in the upper display. Press the DOWN key and **tSt1** will be displayed. This test can be initiated at this time or press the SCROLL key to advance to the desired test. Test 1, 2 and 3 are performed as a block so the display will advance from **tSt1** to **tSt4**. During the Test mode, with the exception of Test 5, the lower display will be blank.

All available test procedures are listed in TABLE 5-2 (page 53). Test 1, 2, and 3 are performed on start up, periodically during Control, and on entry into the Test mode. Test 4 is executed on entry into and periodically during the Control mode. These tests can be used as trouble-shooting aids.

TESTMODEFLOWCHART

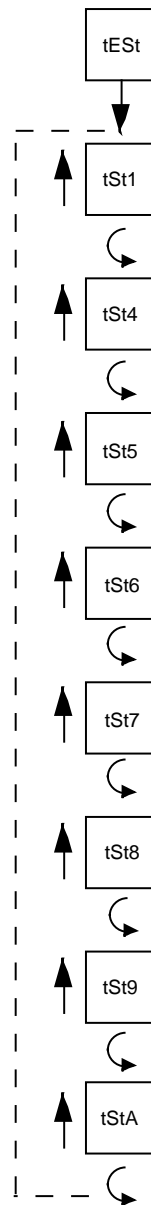
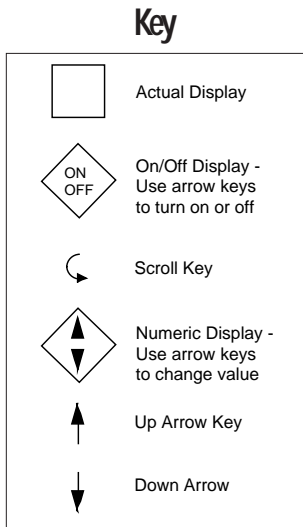

TABLE 5-2 TEST PROCEDURES AND DESCRIPTION

TEST	DESCRIPTION
Test 1	Microprocessor internal RAM test.; used to verify that the processor RAM is functioning correctly.
Test 2	External RAM test; used to test the instrument's RAM for proper function.
Test 3	EPROM checksum test; used to check program for correct data.
Test 4	External RAM checksum test; displays the number of times Error 16 and 17 have occurred.
Test 5	Verifies that all keys are functional and all LED displays are working.
Test 6	Used to verify that all relays and/or solid state relay driver outputs are working.
Test 7	Used to check the operation of Output 1, mA current output.
Test 8	Used to check the operation of Output 2, mA current output.
Test 9	Auxiliary input test; used to test position proportioning (slidewire feedback or remote setpoint voltage levels).
Test A	Communications hardware test; tests the send and receive functions.

5.3.1 TEST 1 - INTERNAL RAM TEST

Checks the Random Access Memory in the microprocessor. No special test equipment is required for this test. With Test 1 displayed **tSt1** press and hold the DOWN key then press the SCROLL key. **tSt1** will be displayed momentarily while the test is in progress. Upon successful completion the instrument will initiate Test 2 automatically.

5.3.2 TEST 2 - EXTERNAL RAM TEST

Checks the operation of the RAM external to the microprocessor. No special test equipment is required. After completion of Test 1, **tSt2** will be displayed momentarily while the test is in progress. Upon successful completion of Test 2, Test 3 will be initiated.

5.3.3 TEST 3 PROGRAM - EPROM TEST

This is a checksum test to verify data integrity of the stored program. No special test equipment is required for this test. After completion of Test 2, **tSt3** will be displayed momentarily while the test is in progress. Upon successful completion the instrument will display **tSt1**.

5.3.4 TEST 4 - EXTERNAL RAM CHECKSUM TEST

This is a checksum test to verify the integrity of data stored in RAM and indicate the number of times the instrument has had an Error 16 or 17. No special test equipment is required for this test. With **tSt4** displayed, press and hold the DOWN key then press the SCROLL key. The display will go blank momentarily, then briefly display two numbers and then **tSt4** will be displayed. These numbers indicate the number of times Error 16 and 17 have occurred respectively. Test 4 can be executed again, or another test may be selected. Test 4 occurs when the instrument enters the Control mode and periodically during Control mode operation.

5.3.5 TEST 5-KEYPAD/DISPLAY TEST

This test allows the operator to verify that the keys work and that all display elements can be lighted. No special test equipment is required for this test. With **tSt5** displayed press and hold the DOWN key then press the SCROLL key. The display will go blank. Release both keys, then press each key to be tested.

<u>KEY</u>	<u>DISPLAY</u>
SCROLL	SCrL
UP KEY	uAro
DOWN KEY	dAro
UP AND DOWN KEYS	ALL LED's AND SEGMENTS LIGHTED, both displays
AUTO/MANUAL	Auto
AUTOTUNE	Atun
SP1/SP2	SP

To exit Test 5, press the SCROLL and UP key simultaneously. **tSt5** will be displayed.

5.3.6 TEST 6 RELAY/SSR DRIVER OUTPUT TEST

Verifies that the Relay/SSR Driver output(s) are working. A volt/ohm meter will be useful to verify the output operation. With **tSt6** displayed press and hold the DOWN key then press the SCROLL key. **oFF** will be displayed. For SPST relay outputs, connect the volt/ohm meter, set to ohms, across the relay outputs. For SSR driver outputs, connect the volt/ohm meter across the output terminals in the volt/DC mode. Depress the DOWN key repeatedly to advance through the following sequence:

<u>DISPLAY</u>	<u>RELAY ON</u>
rLYA	A Only
rLYb	B Only
rLYC	C Only
oFF	None

The relays should be checked for continuity when on and high impedance when off. SSR drivers will output 5 VDC when on and 0 VDC when off. This sequence may be repeated by using the DOWN key. To exit press the SCROLL key and **tSt6** will be displayed. The existence of relay SSR outputs is dependent upon the hardware configuration.

5.3.7 TEST 7-CURRENT OUTPUT 1 TEST

This test allows the user to verify that current Output 1 is functioning properly and will allow the adjustment of the current output value for testing of associated equipment. A volt meter with an appropriate shunt resistor or milliamp meter will be needed to execute this test. With **tSt7** displayed depress and hold the DOWN key, then press the SCROLL key. Connect the DVM or milliamp meter across the output terminals 5 and 6. The display will indicate **4** milliamps output. Use the UP and DOWN keys to vary the output in 1mA steps. The current output reading should be +/- 0.5mA at any output value. To exit the test, press the SCROLL key and "**tSt7**" will be displayed. The existence of the mADC current output is dependent upon the hardware configuration as indicated by the model number.

5.3.8 TEST 8-CURRENT OUTPUT 2 TEST

This test is the same as Test 7 except for Output 2. Check the output at terminals 7 and 5.

5.3.9 TEST9-AUXILIARY INPUT TEST

This test allows the operator to verify that the auxiliary inputs used for position proportioning (slidewire) feedback or remote setpoint is functioning properly. A variable voltage source, 5 VDC will be required to execute this test. With **tSt9** displayed, press and hold the DOWN key then press the SCROLL key. The Auxiliary input voltage will be displayed to the nearest hundredth of a volt. Connect the +5V source across the Auxiliary input terminals (terminals 8 and 5) and adjust the voltage. Verify that the voltage displayed changes accordingly. The displayed voltage should be typically 0 - 5VDC +/- 0.3 volts. To terminate the test, press the SCROLL key. The display will show **tSt9**.

The existence of the auxiliary input tested in Test 9 depends upon the hardware configuration as indicated by the model number.

5.3.10 TESTA-COMMUNICATIONS HARDWARE TEST

(Communications Option only)

This test allows the operator to verify that the communications hardware is functioning properly. With **tStA** displayed, press and hold the DOWN key then press the SCROLL key. The display will indicate **SEnd**. Each time the DOWN key is depressed, the unit will toggle between **SEnd** and **rEC** (receive). With the desired function selected, depress the SCROLL key.

In the **SEnd** (send or transmit) mode, the instrument will repeat the following sequence. First, the transmitter will go logic 1 for one second. Next, the transmitter will change the logic level to 0 for one second. Then, the transmitter will be disabled for one second. In the **rEC** mode, the transmitter will be disabled. In either mode, the instrument will monitor the line logic level. The display will be **rEC0** when a logic 0 is on the line. The display will be **rEC1** when logic 1 is on the line. In the **SEnd** mode, the unit will display **rEC** when the transmitter is disabled.

To perform an internal test to verify the operation of the hardware, place the instrument in the Send mode. Verify that the display cycles through **rEC1**, **rEC0**, and **rEC**. To verify that the transmitter functions properly, two LED's, each with a current limiting resistor, can be connected to the communications terminals, with their polarities connected opposite of each other. The following three states will be produced: one LED on, then the other LED on, then both off. Alternately, a load resistor can be placed on the terminals, the voltage generated across the load resistor is as follows: > +3 VDC then > -3VDC and then 0 VDC. The terminals used depends on the hardware ordered, either 8 and 7 or G and H.

Another test method, would be to connect one or more instruments in the Receive mode to an instrument in the Send mode. The instruments in the Receive mode should have their display alternating in sync with the instrument that is in the Send mode. When the sending unit displays **rEC**, the receiving units should display **rEC1**.

To terminate the test, press the SCROLL key for one second. Upon exit, **tStA** will be displayed.

Trouble-shooting and Diagnostics 5.4

This section consists of two columns. The first column is a list of some possible instrument conditions. The second column is a list of steps that should improve the condition. The steps should be performed in order until the condition improves or all the steps have been tried. If the instrument condition has not improved, contact the nearest representative or the factory for assistance.

Trouble-shooting should be performed by qualified personnel using the proper equipment and following all safety precautions. Whenever possible, the trouble-shooting should be accomplished with the electrical power disconnected. The instrument contains static sensitive components so care should be taken to observe anti-static procedures.

Condition

Display is blank (dark)

Correction Steps

1. Verify that the correct instrument power, as indicated on the wiring label on the housing, is supplied to terminals A & B. If the voltage is not correct, check the power source.
2. Turn off the instrument power. Wait about 5 seconds, then turn the power on again.
3. Turn off the instrument power, loosen the front panel screw, and remove the instrument from the housing. Inspect the instrument for poor connections.
 - a. The white ribbon cable that connects the Processor board (Appendix A-2, page 65) to the Power Supply Board (Appendix A-1, page 64) must be properly aligned and seated.
 - b. The Front Display board pins should be properly aligned and seated in the sockets on the Processor board (Appendix A-2, page 65) and the Power Supply board (Appendix A-1, page 64).
 - c. The Display Driver (U-1), located on the Display board, must be free of corrosion and firmly seated in the socket. Reinsert the instrument in the housing, tighten the panel screw, and turn on the power.
4. Turn off the instrument power. Press and hold the UP and DOWN keys. Turn on the power. Hold the keys depressed for about 10 seconds. If the display lights the model number, Program and Tune mode parameters will need to be re-entered (page 29 & 35 or the Software Ref. Sheet, page 77, if already filled out).

Model Number Displayed is incorrect

Note: To re-initialize, follow steps 2 and 3.

1. Turn off the instrument power, wait 5 seconds then reapply the power. Verify that the number displayed during the power up sequence is the same as indicated on the label affixed to the lower front of the display bezel.
2. Turn off the power to the instrument. Press and hold the UP and DOWN keys and turn on the power. Keep the keys depressed until the model number resets to **8200**. Release the keys and turn off the power.

3. To enter the correct model number press and hold the SCROLL and DOWN keys and turn on the instrument power, **8200** should be displayed. Wait about 5 seconds and release the keys. The display should remain **8200**. Use the UP/DOWN keys as necessary to change the displayed number to match the first 4 digits of the model number. After adjusting the first 4 digits to the proper values, press the SCROLL key and the display will change to **000-**. Use the UP/DOWN keys to set the last 3 digits of the model number to the correct values. Press the SCROLL key and the power up sequence will complete. The Program and Tune mode parameters will need to be re-entered (page 29 & 35 or the Software Ref. Sheet, page 77, if already filled out).

Relay/SSR Driver Output(s)
Malfunction

1. Verify that the Program and Tune mode parameters are correctly set (pages 29 & 35 or the Software Ref. Sheet, page 77, if already filled out).
2. Turn off the power to the instrument. Wait about 5 seconds and turn the power on again. Confirm that the model number displayed during the power up sequence indicates that the output(s) is/are present in the instrument. This number should match the number on the label affixed to the lower front of the display bezel. If model # is incorrect, follow steps for "**Model # displayed is incorrect**".
3. Turn off the power to the instrument. Loosen the front panel screw and remove the unit from the housing. Inspect the Power Supply board (Appendix A-1, page 64) for the presence of the output device(s). Relay A is located at K1, Relay B at K2, and Relay C at K3. A relay output will appear to be a cube. The SSR Driver will appear as a resistor and a jumper wire. The output will not work if the hardware is not present.
4. Check the output operation by performing Test 6 as described in the Test section (page 54). If the output(s) function(s) in the Test Mode re-examine the Program and Tune Mode Parameters settings (page 29 & 35, or the Software Ref. Sheet, page 77, if already filled out).
5. If the output appears not to turn off remove the power to the instrument. Loosen the front panel screw and take the unit out of the housing. Clip the resistor located on the Power Supply board (Appendix A-1, page 64) for the output(s) that seem to stay on. A .01 microfarad, 1 KV should be connected from the terminal listed below, for the output where the resistor indicated was removed, to the AC ground.

Relay A	R12	Terminal C
Relay B	R13	Terminal E
Relay C	R14	Terminal G

Return the instrument to the case and tighten the front panel screw. Turn the power on to the instrument and check the operation of the output(s).

mADC Output(s)
Malfunction

1. Verify that the Program and Tune mode parameters are correctly set (page 29 & 35 or the Software Ref. Sheet, page 77, if already filled out).
2. Turn off the power to the instrument . Wait about 5 seconds and turn the power on again. Confirm that the model number displayed during the power up sequence indicates that the output is present in the instrument. The number should match the model number on the label located on the lower front of the display bezel. If model # is incorrect, follow steps for "**Model # displayed is incorrect**" (page 56).
3. Turn off the power to the instrument. Loosen the front panel screw and remove the unit from the housing. Inspect the Option board (Appendix A-3, page 66 and 67) for the presence of the Current Output Driver IC. Current 1 output is U-1 and Current 2 output is U-5. The current output cannot function without the hardware being present . Return the instrument to the housing and tighten the front panel screw.
4. Refer to the Test section (page 52) and carry out the procedure for the output(s) that is/are not working. Test 7 operates current Output 1 and Test 8 for current Output 2. If the current output operates properly in the Test mode re-check the Program and Tune mode parameters (page 29 & 35 or the Software Ref. Sheet, page 77, if already filled out).

Error Code Displayed - The display of error codes except Er 40 - 60 will cause on/off outputs to turn off and proportional outputs to be the value selected in the Program Mode parameters P1EC and/or P2EC

SnSr
Sensor Break or out of range

1. Inspect the sensor for proper operation and connection to the instrument. Acceptable sensor ranges for the instrument are listed in the Specifications section of Appendix D (page 73).
2. Verify that the Program Mode input selection matches the sensor input connected.
3. Check that the input conditioning jumpers on the Processor board (Appendix A-2, page 65) and the Option Board (Appendix A -3, page 66 and 67) are in the proper position for the sensor input.
4. Perform the calibration procedure(s), as described in the Calibration section (page 48) , for the sensor input type.

rSEr
Remote Setpoint Error

1. Check that the Remote Setpoint signal is present and of the polarity between terminals 8 (+) and 5 (-).
2. Perform the Auxiliary Input Test, Test 9 as described in the Test section (page 55), the voltage indicated during the test should be the same as measured in the preceeding step.
3. Verify that the Remote Setpoint input voltage range selected in the Program Mode (page 29) is the same as the voltage that is present at the Remote Setpoint input terminals.

FbEr Slidewire Feedback Error	<ol style="list-style-type: none"> 1. Inspect the Slidewire Feedback connections at terminals 8, 7, and 5. Be sure that the connections are the same as shown in the position proportioning illustration (page 20). 2. Measure the resistance of the Slidewire segment. The minimum resistance must be 135 ohms, the maximum 10 K ohms. 3. Perform the Auxiliary Input Test. Test 9 as described in the Test section, (page 55) the voltage indicated should be between 0 and 5 VDC. 4. Turn off the power to the instrument. Loosen the front panel screw and take the instrument out of the housing. Verify that the jumper JU-1 on the Option Board (Appendix A-3, page 66 and 67) is in the Motor Modulation position.
Hi - Input more than 10% Over Span	<ol style="list-style-type: none"> 1. Perform the steps listed for the SnSr error condition (page 58).
Lo - Input more than 10% Under Span	<ol style="list-style-type: none"> 1. Perform the steps listed for the SnSr error condition (page 58).
6̄ - display overrange (the "broken 6" appears on the left side of the display)	<ol style="list-style-type: none"> 1. If this error code is displayed as a Program or Tune mode parameter value, perform the Cal 1 procedure as described in the Calibration section (page 48). 2. If this error code appears as part of the model number during the power up sequence, follow the steps listed for the "Model number incorrect" condition (page 56).
Er 1 - Microprocessor RAM Failure	<ol style="list-style-type: none"> 1. Turn off the power to the instrument. 2. Loosen the front panel screw and remove the instrument from the housing. Inspect that the microprocessor (U1) is properly seated in the socket located on the Processor board (Appendix A-2, page 65). Return the instrument to the housing and tighten the front panel screw. Turn on the power.
Er 2 - External RAM Failure	<ol style="list-style-type: none"> 1. Turn off the power to the instrument. Wait 5 seconds, and turn the power on.
Er 3 - EPROM Checksum Failure	<ol style="list-style-type: none"> 1. Perform the steps listed for Er 1 except that the EPROM (U2) on the Processor board should be inspected.
Er 4 - RTD Mismatch Error	<ol style="list-style-type: none"> 1. Check the connections to the instrument for the RTD Input Calibration CAL5 as described in the Calibration section (page 51). Repeat the RTD Input Calibration.
Er 5 - No Zero Crossings Detected	<ol style="list-style-type: none"> 1. Turn off the power to the instrument. Wait 5 seconds and turn the power on. 2. Turn off the instrument power. Loosen the front panel screw and remove the instrument from the housing. Inspect the white ribbon cable that connects the Processor board to the Power Supply board. Be sure that the cable is properly aligned and seated in socket on the Power Supply board. Return the instrument to the housing and tighten the front panel screw. Turn on the power to the instrument. 3. Connect the instrument to another AC power source.

Er 6 - AC line below 45 HZ	<ol style="list-style-type: none"> 1. Turn off the power to the instrument. Wait 5 seconds and turn the power on. 2. Turn off the instrument power. Loosen the front panel screw and remove the instrument from the housing. Inspect the white ribbon cable that connects the Processor board to the Power Supply board. Be sure that the cable is properly aligned and seated in the socket on the Power Supply board. Return the instrument to the housing and tighten the front panel screw. Turn on the power to the instrument. 3. Connect the instrument to another AC power source.
Er 7 - AC line over 65 HZ	<ol style="list-style-type: none"> 1. Turn off the power to the instrument. Wait 5 seconds and turn the power on. 2. Turn off the instrument power. Loosen the front panel screw and remove the instrument from the housing. Inspect the white ribbon cable that connects the Processor board to the Power Supply board. Be sure that the cable is properly aligned and seated in the socket on the Power Supply board. 3. Connect the instrument to another AC power source.
Er 8 - Cal 2 Volt Input Error	<ol style="list-style-type: none"> 1. Check that 50 mVDC is properly connected to the instrument and is within the tolerance limits as indicated in the CAL 2 procedure of the Calibration section (page 50). 2. Loosen the front panel screw and remove the instrument from the housing. Inspect the Processor board (Appendix A-2, page 65) to insure that the input conditioning jumper JU 1 is in the non-volt position. 3. Perform the CAL 2 procedure as described in the Calibration section (page 50).
Er 9 - ADC Reference Number Error	<ol style="list-style-type: none"> 1. Turn off power to the instrument, wait 5 seconds, then turn the power on.
Er10 - ADC Reference Voltage Error	<ol style="list-style-type: none"> 1. Turn off power to the instrument, wait 5 seconds, then turn the power on.
Er 11 - Cold Junction Compensation Error	<ol style="list-style-type: none"> 1. Be sure the Cold Junction Sensor is firmly attached to terminals 2 and 4. 2. Perform the CAL 3 procedure as described in the Calibration section (page 50).
Er 12 - CAL 2 Voltage Error	<ol style="list-style-type: none"> 1. Check that 50 mVDC is properly connected to the instrument and is within the tolerance limits as indicated in the CAL 2 procedure of the Calibration section (page 50). 2. Loosen the front panel screw and remove the instrument from the housing. Inspect the Processor board (Appendix A-2, page 65) to insure that the input conditioning jumper JU1 is in the non-volt position. 3. Perform the CAL 2 procedure as described in the Calibration section (page 50).

Er 13 - RTD CAL 5 Input Error	<ol style="list-style-type: none"> 1. Check that the resistance device is of the correct value and properly connected to the instrument and is within the tolerance limits as indicated in the CAL 5 procedure of the Calibration section (page 51). 2. Loosen the front panel screw and remove the instrument from the housing. Inspect the Processor board (Appendix A-2, page 51) to insure that the input conditioning jumper JU1 is in the non-volt position and that the Option board jumpers JU2 and JU3 are in the RTD position. 3. Perform the CAL 5 procedure as described in the Calibration section (page 51).
Er 14 - Cold Junction Compensation Error	<ol style="list-style-type: none"> 1. Be sure the Cold Junction Sensor is firmly attached to terminals 2 and 4. 2. Perform the CAL 3 procedure as described in the Calibration section (page 50).
Er 15 - Ground Reference Tolerance Error	<ol style="list-style-type: none"> 1. Turn off power to the instrument, wait 5 seconds, then turn the power on.
Er 16 - Program/Tune Mode Checksum Error	<ol style="list-style-type: none"> 1. Record all Program and Tune mode Parameters. Perform the CAL 1 procedure as described in the Calibration section (page 49). Re-enter the Program and Tune mode Parameters (page 29 & 35 or the Software Ref. Sheet, page 77, if already filled out).
Er 17 - Calibration Checksum Error	<ol style="list-style-type: none"> 1. Perform the calibration procedures that are needed for the input sensor that will be used.
Er 20 - Setpoint Validation Error	<ol style="list-style-type: none"> 1. Use the UP or DOWN key to change the setpoint value.
Er 36 - Incorrect Crystal For Digital Comm.	<ol style="list-style-type: none"> 1. Turn off the power to the instrument, wait 5 seconds, then turn the power on.
Er 37 - Incorrect Micro. For Digital Comm.	<ol style="list-style-type: none"> 1. Turn off the power to the instrument, wait 5 seconds, then turn the power on.
Er 40 - Process Value not 20 Degrees below Setpoint Value	<ol style="list-style-type: none"> 1. Auto Tune will not function unless the process value is at least 20 degrees below the setpoint value when the Auto Tune Select ASo, is set for 0. Changing the ASo to 1 will allow the Auto Tune to function when the process value is within 20 degrees of setpoint.
Er 41 - Process Value not 5 % of the Setpoint Value Below the Setpoint Value	<ol style="list-style-type: none"> 1. Auto Tune will not function unless the process value is at least 5 % of the setpoint value below the setpoint when Auto Tune Select is set for 0. Changing the ASo to 1 will allow the Auto Tune to function when the process value is within 5 % of the setpoint value below setpoint.
Er 42 - Process Value not Below the AduL value from Setpoint	<ol style="list-style-type: none"> 1. The Auto Tune will not function unless the process exceeds the Auto Tune Deviation from setpoint value, selected in the Program Mode, if ASo is selected as 0. Changing the ASo value to 1 will allow the Auto Tune to function when the process value is within the AduL range of the setpoint value.

Er 43 - Setpoint above ASuL value	1. Auto Tune will not function if the Setpoint value is greater than the Auto Tune Setpoint Upper Limit ASuL selected in the Program mode. Increase the ASuL value to be greater than the desired setpoint.
Er 44 - Setpoint value ASLL value	1. Auto Tune will not function if the Setpoint value is less than the Auto Tune Setpoint Value ASLL selected in the Program mode. Decrease the ASLL value to be lower than the desired setpoint.
Er 45 - Incorrect Output Selection(s)	1. Auto Tune will not function unless the Output Configuration, in the Program mode is correct. Output 1 must be selected as 4, 6 or 7 depending on the instrument hardware and the application. Output 2 cannot be 2, 4 or 6. (If Output 1 = 7, then Output 2 must be 7).
Er 46 - Setpoint Ramp Rate Feature in Use	1. Auto Tune will not function if the Setpoint Ramp Rate feature has been enabled. For the Auto Tune to function the Setpoint Ramp Rate feature must be selected as 0.
Er 47 - Not in Control or Standby Mode	1. Auto Tune will not function unless the instrument is in the Control or Standby modes. Be sure that the instrument is in either of these modes and re-attempt the Auto Tune.
Er 48 - Auto Tune is not Enabled	1. Auto Tune will not function if Auto Tune mode is not Enabled. Enable the Auto Tune mode and re-attempt the Auto Tune. Refer to the Enable mode section of the manual (page 24) for instructions on how to Enable the Auto Tune feature.
Er 49 - Output(s) Not Selected Properly	1. Auto Tune will not function unless the Output Configuration, in the Program mode is correct. Output 1 must be selected as 4, 6 or 7 depending on the instrument hardware and the application. Output 2 cannot be 2, 4 or 6. (If Output 1 = 7, then Output 2 must be 7).
Er 53 - Process Value Not Increasing	1. The Auto Tune feature must sense an increasing process response to calculate the Tune mode parameter values. Check the control device for proper operation and re-attempt the Auto Tune (page 36).
Er 54 - Process Value Not Decreasing	1. The Auto Tune feature must sample a decreasing process response during part of the Auto Tune function to calculate the Tune mode parameter values. Check the control device for proper operation and re-attempt the Auto Tune (page 36).
Er 55 - Auto Tune Time Out	1. The Auto Tune was unable to complete the calculations within the time allowed in the Auto Tune Time Limit AtL parameter in the Program mode. Increase the time limit value and re-try the Auto Tune (page 36).

Er 56 - Process Overshot the Setpoint	<ol style="list-style-type: none"> 1. The process value exceeded the setpoint value too quickly for the Auto Tune calculations to complete. <ol style="list-style-type: none"> a) Lower the process value further before re-attempting Auto Tune (page 36). b) If not used, select out2 =3 or 5 then re-attempt Auto Tune (page 36). c) Reduce the o1uL percentage of output value in steps of 10% and re-attempt Auto Tune until Er56 doesn't appear (page 36).
Er 57 - Failed Noise Test	<ol style="list-style-type: none"> 1. The process response samples are checked to detect erroneous values that might be caused by noise on the sensor input. If noise is detected the Auto Tune will abort. Inspect the instrument and the sensor for proper installation. Re-attempt the Auto Tune (page 36).
Er 58 - Cancelled by Operator	<ol style="list-style-type: none"> 1. If the AUTO TUNE key is pressed while the Auto Tune feature is active the Auto Tune will abort. Re-attempt the Auto Tune (page 36).
Er 59 - Error Occurs During Auto Tune	<ol style="list-style-type: none"> 1. If a non-Auto Tune Error condition occurs while the Auto Tune is active, the Auto Tune will abort. Clear the error condition and re-try the Auto Tune (page 36).
Er 60 - Power Interrupt Auto Tune	<ol style="list-style-type: none"> 1. If the instrument power goes off while the Auto During Tune is active it will cause the Auto Tune to abort. Re-attempt the Auto Tune (page 36).
Momentary Er 70 - Controller unable to respond within 250 milliseconds	<ol style="list-style-type: none"> 1. Tried to communicate while unit was in a non-control mode.
Momentary Er 71 - Byte received before the response was transmitted	<ol style="list-style-type: none"> 1. The unit received a request before proper amount of time has elapsed since last request.
Momentary Er 72 - Incorrect Block Check character was received	<ol style="list-style-type: none"> 1. Data received not valid, possible corruption on the commlink. Possible noise.
Momentary Er 73 - Byte received with incorrect parity	<ol style="list-style-type: none"> 1. Improper parity selection on the transmitting terminal. 2. Incorrect baud rate. 3. Noise.

Appendix A Board Layout - Jumper Positioning

FIGUREA-1 - Power Supply Board

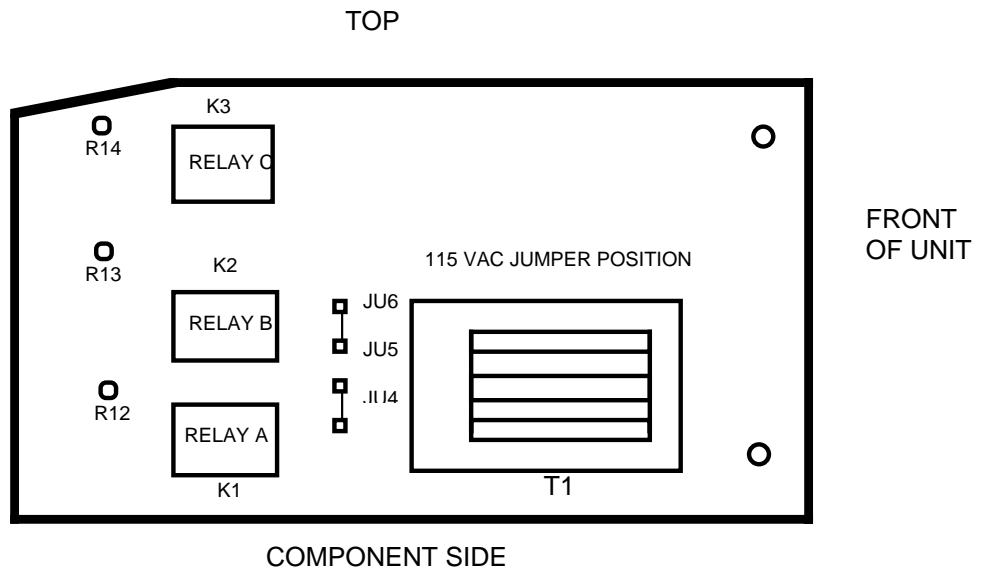

230 VAC UNITS MAY BE
FIELD CONVERTED
TO 115 VAC BY MOVING
JUMPERS AS SHOWN
ABOVE .
(115 VAC UNITS CANNOT
BE FIELD CONVERTED TO
230 VAC!!)

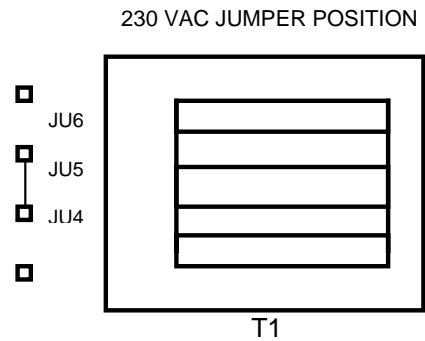

FIGUREA-2-ProcessorBoard

Revision L, M, and M2

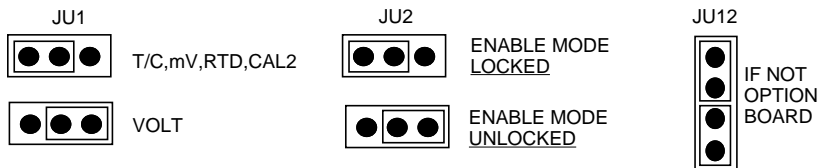
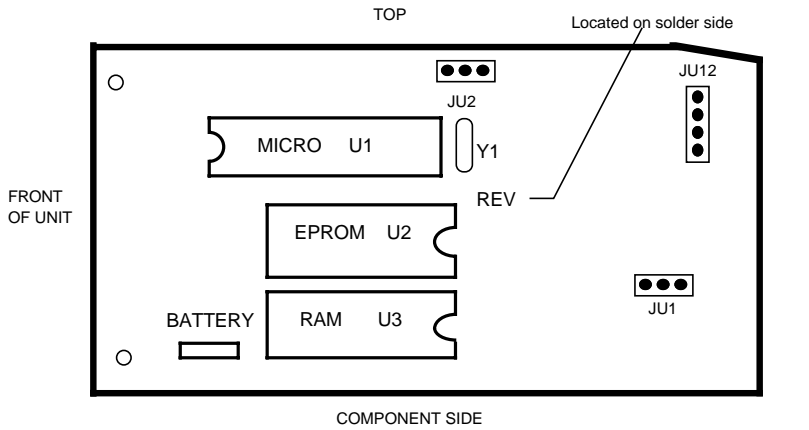

Note: Locked and unlocked positions differ from Rev J and below and M3 and above.

Revision J and below AND M3 and above

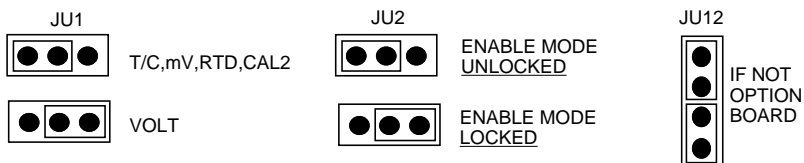
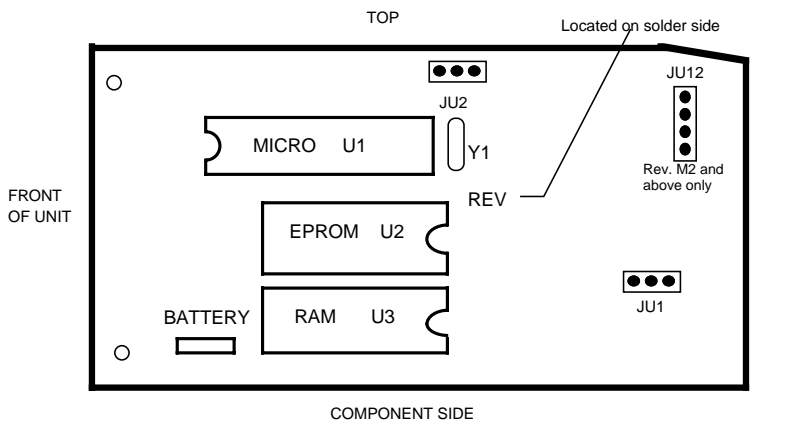

FIGUREA-3 - OptionBoard, Revision E and above

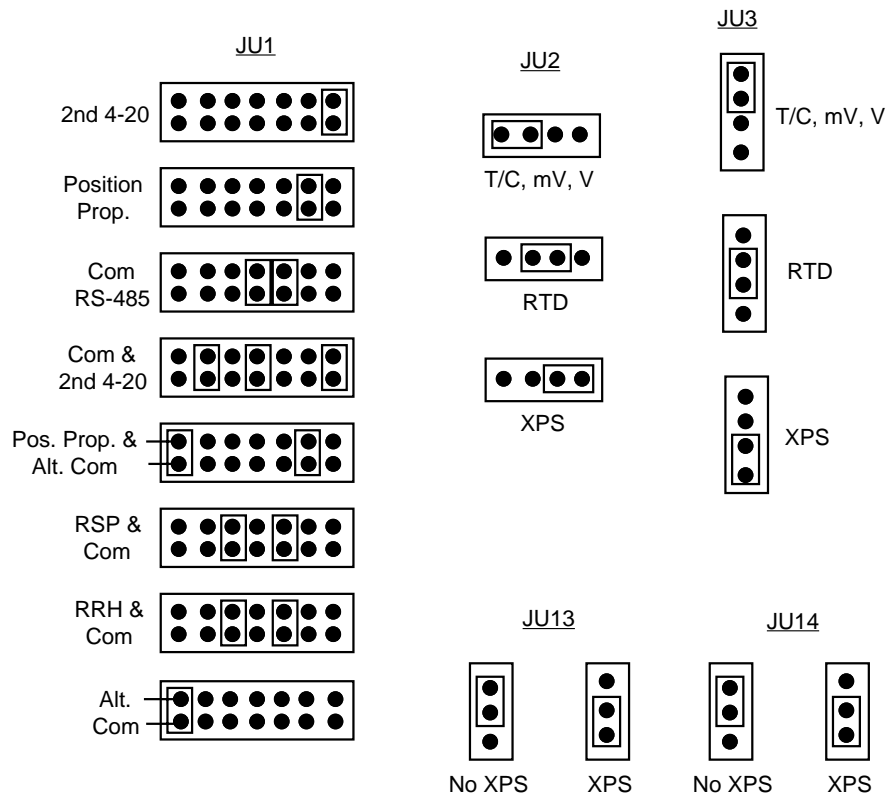
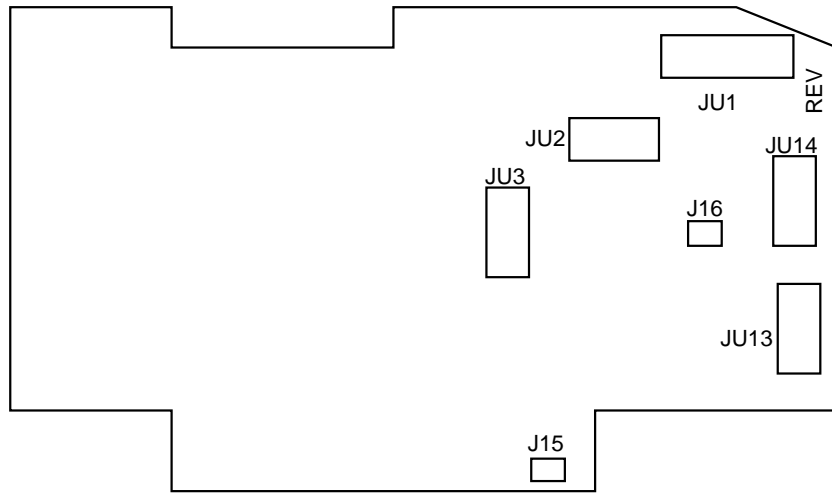

J15 - AC Input XPS cable from transformer
 J16 - XPS to Relay C

FIGURE A-3-OptionBoard, Revision D and below

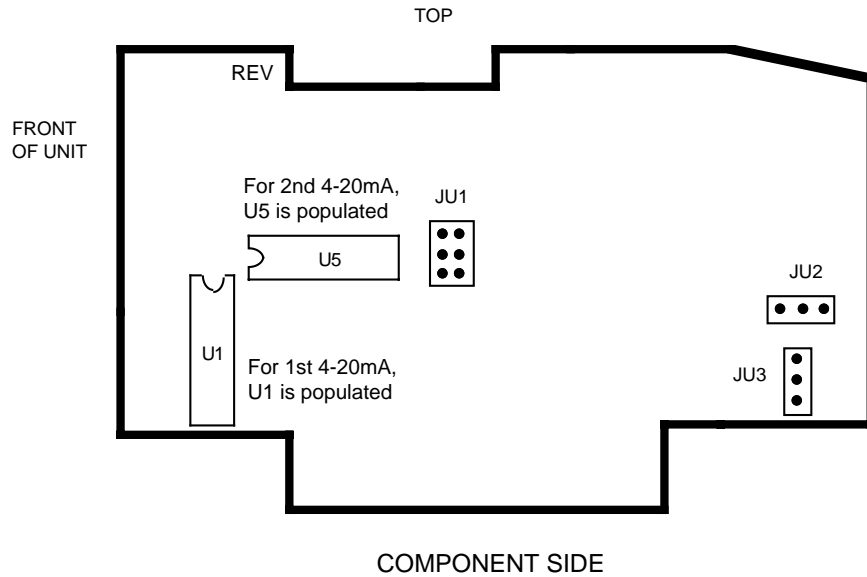

JU1

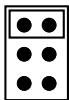

2ND 4-20 mADC

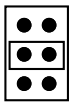

MOTOR MODULATION/
POSITION PROPORTIONING
POTENTIOMETER REMOTE
SETPOINT



DIGITAL
COMMUNICATIONS
422/485

JU2



RTD



JU3 T/C, mV, VOLT
(NON-RTD)

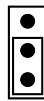

RTD



T/C, mV, VOLT
(NON-RTD)

Appendix B

Glossary of Terms

Automatic Reset (Integration)

Automatic reset is a Tune mode parameter that will bias the proportional output(s) to compensate for process load variations. This parameter is adjustable from 0.0 to 100.0 repeats per minute. Factory default is 0.0. The display codes are **ArS1** for proportional Output 1 and/or **ArS2** for proportional Output 2. The Auto Tune feature will select the **ArS1** setting for a heating output.

Automatic Transfer

Automatic transfer is a feature selected in the Program mode that will allow the instrument to shift from the Manual to the Control mode of operation automatically when the process value reaches setpoint.

Auto Tune

Auto Tune automatically determines the Tune mode parameters for a proportional heating output assigned to Output 1. The Ziegler - Nichols method is used to determine the Tune mode parameters.

Auto Tune Deviation Lower Limit

If **AdLL** = 0, when the AUTO TUNE key is pressed, the process response calculations will occur during the time the process variable rises to the point 1/2 of the way between the setpoint value and the process value when the key was pressed.

If **AdLL** > 0, when the AUTO TUNE key is pressed the process response calculations will begin when the process value rises above the point that is the result of subtracting **AdLL** from setpoint.

Auto Tune Deviation Upper Limit

If **ASo** = 0, the Auto Tune function will not operate unless the process value is < the SP-**AduL** value. This can be useful to prevent unwanted retuning of the process when the process value (PV) is > the Setpoint value minus the **AduL** value.

If **ASo** = 1, Auto Tune will function if the PV is within the **AduL** value from setpoint. However, if the PV is > SP-**AduL**, the heating output will be turned off until the PV < SP-**AduL**. At this point the heating output will be turned on so the control response can be calculated.

In order for **AduL** to have an effect on Auto Tuning, the **AduL** value should be greater than 20 degrees or 5 % of the setpoint value, whichever is greater, to initiate the Auto Tune function.

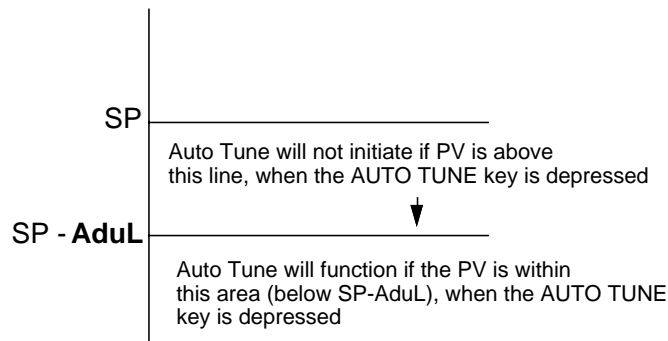

ASuL and **ASLL** are Program mode parameters that can be used to establish upper and lower setpoint values outside of which the Auto Tune feature will not function. The Auto Tune feature will not function if the process value is greater than **ASuL** or below **ASLL**.

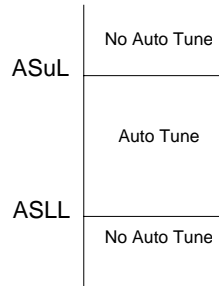

Auto Tune Time Limit

This feature is used to automatically abort the Auto Tune function if the control response calculations have not been completed within the time allotted.

Balanceless Transfer

This feature prevents changes in proportional output when changing from the Manual to Control mode of operation. When transferring from the manual mode to the control mode, the proportional outputs will be "Balanceless" regardless of whether the unit is inside or outside the proportional band. This only holds true if the Auto Reset (ArSt) value is greater than 0.

Bumpless Transfer

This feature prevents changes in proportional outputs when changing from the Control to the Manual mode of operation.

Choice of Control Algorithm

This Program mode parameter is used to select the control algorithm that will be used for Auto Tune calculations.

Control selections are PID, PI, or P only . PI is the factory default.

Control Algorithm

A pre-programmed series of instructions that are used by the instrument when determining the status of the output(s).

Control Response Criteria

This Program mode parameter selects the type of control response desired for the application when using the Auto Tune feature.

The control response selections are from 1.0 for 1/4 wave decay response to 2.0 which is a damped response.

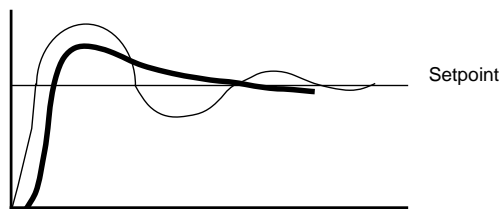

CRC - Control Response Criteria
available settings
 — 1.0 = 1/4 Wave Decay Response
 — 2.0 = Damped Response

NOTE: Actual damped response may vary depending on the control system and the application.

Cycle Time

This Tune mode parameter is used to select the on/off cycle time for time proportioning outputs (**Ct1** for Output 1 and/or **Ct2** for Output 2). (See page 41, Section 4.5)

When using the Position Proportioning option, **Ct1** must be selected for the stroke time of the motor.

Deviation Band Alarm (Output 3)

This feature can be used to provide an indication that the process value has deviated outside of a selectable deviation tolerance band value that straddles the setpoint. If in the Program mode **out3** is selected as 5, an assigned output will be off as the process value is within the deviation band about the setpoint. The output will turn on if the process value falls below or goes above the deviation band about the setpoint. The amount of the deviation band is selected in the Tune mode parameter, **dbAL**.

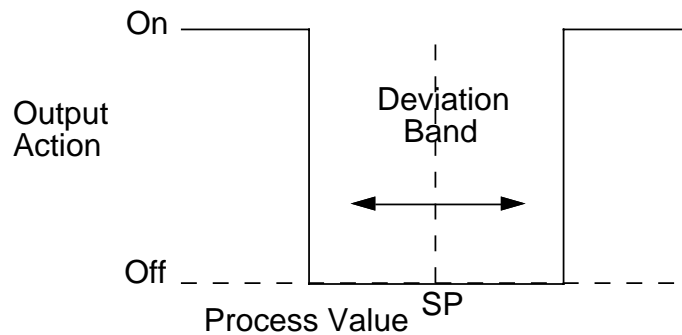

If **out3** is selected as 6, an assigned output will be on as long as the process value is within the deviation band about the setpoint. The output will turn off if the process value falls below or goes above the deviation band about the setpoint. The deviation band value is selected in the Tune mode, **dbAL**.

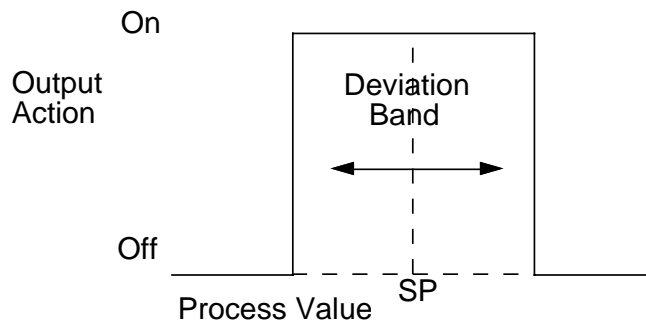

Display Filter Factor

This Program mode parameter is used to dampen the process value displayed. The selections range from 1 through 20, the value represents the number of process scans that will be averaged for the display value. Factory default is 1, no filtering.

Engineering Units Upper and Engineering Units Lower

These Program mode parameters are used with volt, millivolt, and milliamp inputs. The Engineering Units Upper **EuU** should be selected as the value to be displayed when the input is at maximum. The Engineering Units Lower **EuL** should be selected as the value to be displayed when the input is at minimum.

First Output Position

This parameter is adjustable from -1000 to 1000 units and represents a shift or offset of the on-off actuation points or proportional band for the first output relative to the normal position. For example, a negative value could be used to offset an expected overshoot. First OutputPosition also shifts the proportional band with respect to the process value range output of which integral action is inhibited. Factory default is 0. Display code is **FoP**.

Hysteresis for Alarm Outputs

This Program mode parameter is used to create a deadband for the alarm output(s). For example, a process direct alarm is selected for 200 °/units with a **HyAo** set for 20°/units. The output assigned will turn on when the process value exceeds 210°/units. The output will turn off when the process value goes below 190°/units.

Be aware that this parameter will also effect the output action if used as a Deviation or Deviation Band Alarm. (i.e.the Deviation Band will be increased by the amount of **HyAo** selected)

This parameter is adjustable from 0 to 300 °/units. The factory default is 3. The display code is **HyAo**.

Hysteresis for Control Outputs

This Program mode parameter is used to create a deadband for On/Off control outputs. This parameter is adjustable from 0 to 300 degrees/units. Factory default is 3. This feature can be used to reduce the cycling of the on/off outputs. The display code is **HyCo**.

Input Correction

This parameter is used to adjust the process variable value to compensate for sensor errors. This Program mode parameter is selectable from -300 to + 300 degrees/units. The factory default is 0. The display code is **iCor**.

Manual Reset

This parameter is adjustable from -1500 to 1500 units representing a manual shift of proportional band(s) relative to the normal position. Manual reset is intended to be used when automatic reset is not used to allow compensation for deviations from setpoint which remain after the process has stabilized. Factory default is 0. Increasing the value increases the process variable, i.e. if the process variable stabilized too low, increase the manual set. Integral action, and conversely reset-windup inhibit apply over the same process value range regardless of the manual reset value. The display code is **rSt**.

Process Filter Factor

This Program mode parameter is used to dampen the process value used to calculate output action. The process value is averaged to dampen the control outputs. This parameter is adjustable from 1 to 20 . Factory default is 1. The display code is **PFF**.

Process Retransmission Output

This parameter allows for a linear milliamp proportional output relative to the process value. The current output may be scaled over a range selectable by the user. This output can be used to supply the process variable signal to remote chart recorders, panel meters, and data logger instruments.

Process Rounding

This Tune mode parameter is used to determine the step size of the process value that will be seen on the display. This feature can be used to reduce display fluctuation. This parameter is adjusted from 1 to 100 degrees/units. The factory default is 1, no rounding (e.g. Process rounding = 2, Process Value Display - 4, -2, 0, 2, 4, etc.).

Process Variable

The process variable refers to the condition of the process being measured (sensed). The instrument will accept process inputs other than temperature (pressure, level, flow, etc.).

For the Auto Tune feature to work, the process value must be temperature from a thermocouple or an RTD.

Proportional Band

This Tune mode parameter selects the span of the proportional output range. This parameter is adjustable from 1 to 3000 degrees/units. Factory default is 100. If Output 1 is selected as a proportional output, a display code of **Pb1** will be seen. If Output 2 is selected as a proportional output, the display code will be **Pb2**. The **Pb1** value will be automatically selected if the Auto Tune function is used.

Rate (Derivative)

This Tune mode parameter is adjustable from 0.0 to 10.0 minutes. The value selected represents how much sooner a PID instrument will recover from a process upset than a **PI** only instrument will recover to the same process upset. If Output 1 is selected as a proportional output, **rt1** will be displayed. If Output 2 is selected as a proportional output then **rt2** will be displayed. The **rt1** value will be automatically selected if the Auto Tune function is used.

Second Output Position

This Tune mode parameter is used to shift (deviate) the Output 2 operating point from setpoint. This parameter is adjustable from -1000 to + 1000 degrees/units. Factory default is 0. The display code is **SoP**.

Setpoint Ramp Rate

This Program mode parameter provides a rate of change control of the instrument setpoint value. This parameter is used to inhibit sudden upsets in the instrument control caused by large setpoint changes. This feature also creates a soft start when the instrument power is turned on. The instrument will read the process value at the time the power was turned on as the setpoint value. A rate of change ramp will change the internal setpoint to the setpoint selected.

Appendix C - Order Matrix

8	2						
Output 1 1 Relay 2 SSR Driver 3 4-20mA & Relay 4 4-20mA & SSR Driver		Output 2 0 None 1 Relay 2 SSR Driver 3 4-20mA 4 4-20mA & Relay 5 4-20mA & SSR Driver		Alarm/ Output 3 0 None 1 Relay 2 SSR Driver		Remote 0 None 1 Position Prop. * 2 Remote Setpoint 3 RS 422/485 Std. Com ** 4 RS 422/485 Std. Com *** 5 RS 422/485 Total Access Com** 6 RS 422/485 Total Access Com with Alternate Conn.***	
Voltage 1 115VAC Input & Relays 2 230VAC Input & Relays 3 115VAC Input, 230VAC Relays		Option Suffix None (blank) AB Extended Features Software XP 24VDC Transmitter Power Supply XA 24VDC Power Supply					

* Limited to Model 8211X1X or 8222X1X

** Limited to Model 82X0X3X, 82X1X3X or 82X2X3X and 82X0X5X, 82X1X5X or 82X2X5X. Output 2 cannot be 3,4,5.

*** Limited to Model 82X304X,82X404X, 82X504X and 82X306X, 82X406X, or 82X506X. The Alarm/ Output 3 must be 0.

Appendix D - Specifications

Input Specifications

THERMOCOUPLE

TYPE	RANGE	TYPE	RANGE
J	0 TO 760C 0 TO 1400F	E	0 TO 750C 0 TO 1400F
K	0 TO 1370C 0 TO 2500F	B	200 TO 1800C 400 TO 3300F
T	-200 TO 400C -330 TO 750F	N	0 TO 1300C 0 TO 2370F
R	200 TO 1650C 400 TO 3000F	C	200 TO 2300C 390 TO 4170F
S	200 TO 1650C 400 TO 3000F		

RTD

100 ohm
(.00385 OHM/OHM/C)
-140 to 400C
-220 to 750F

VOLTS

0 to 5 VDC
1 to 5 VDC

MILLIVOLTS

0 to 25 mVDC
0 to 50 mVDC
10 to 50 mVDC

MILLIAMPS

* 0 to 20 mADC

* 4 to 20 mADC is accommodated via the 1-5 VDC input selection with the addition of a shunt resistor.

REMOTE SETPOINT

0 to 5 VDC
1 to 5 VDC

SENSORFAULTDETECTION

Displays **Hi** or **Lo** process input for thermocouple or RTD inputs (10% above or below range) and sensor break, **SnSr**. On/Off outputs go off, proportional outputs go to user selectable output %. Sensor fault detection is not functional for 0 to 5 VDC.

Output Specifications

CONTROL OUTPUT 1 AND 2

Relay Output	SPST 115 VAC: 5.0 A Resistive; 1/8HP or 250 VA 230 VAC: 2.5 A Resistive; 1/8HP or 250 VA
SSR Driver	Open collector output Short circuit protected at 100 mA maximum Provides 4 VDC at 20 mA or 3 VDC at 40 mA
Current Output	0-20mADC or 4-20 mADC into 650 ohms maximum.

ALARM OUTPUT

Relay Output	SPST 115 VAC: 5.0 A Resistive; 1/8HP or 250 VA 230 VAC: 2.5 A Resistive; 1/8HP or 250 VA
SSR Driver	Open collector output Short circuit protected at 100 mA maximum Provides 4 VDC at 20 mA or 3 VDC at 40 mA

Display Specifications

Upper Digital Display	Four (4) 7 segment LED's each; .36 inches high
Lower Digital Display	Four (4) 7 segment LED's each; .36 inches high
Status Indicators	Individual LED indicators for Remote Setpoint, Setpoint 1, Setpoint 2, Process Value, Out 1, Out 2, Manual, Alarm, Degrees F, Degrees C, or Engineering Units, minus sign for negative values (one for each display), Percentage of Output 1, and Percentage of Output 2.

Alarm Adjustment Specifications

Process Alarm	-9999 to 9999 units
Deviation Alarm	-3000 to 3000 units
Deviation Band Alarm	1 to 3000 units

Control Adjustments Specifications

On/Off Hysteresis	0 to 300 units
Proportional Band	1 to 3000 units
Manual Reset	-1500 to 1500 units
Auto Reset Rate	0.0 to 100.0 repeats/minute
Cycle Time	0.0 to 10.0 minutes
Position Proportioning Sensitivity	1 to 240 seconds
First Output Position	0.0 to 50.0 %
Second Output Position	-1000 to 1000 units
	-1000 to 1000 units

Performance Specifications

Measurement Error Limit	<ul style="list-style-type: none"> • Type J,K,T,E,N, & C thermocouples and RTD + or - 0.25% of reading plus 1 degree at 25°C • Type R,S, & B thermocouple + or - 0.25% of span at 25°C • mVDC, mADC and VDC + or - 0.25% of scaled span plus 1 least significant digit at 25 degrees C
Ambient Temp. Error	0.01% of span per degree C deviation from 25 degrees C
Scan Rate	1 scan per second, 3 scan per second selectable
Display Resolution	0 to 3 decimal places (depending upon input type selected)
Auto Reset Windup Inhibit	Auto reset is disabled when the process is outside of the proportional band
Cold Junction Compensation	Self compensation for ambient temperature. All calibration values are stored in memory
Noise Rejection	Normal mode, 85dB minimum at 60 Hz or greater. Common mode, 90dB minimum + /- 24VAC maximum for RTD input, 115 VAC maximum for other inputs
Line Voltage	115/230 VAC + /- 10% 50/60 Hz
Power Consumption	15VA maximum
Operating Temperature	0 to 55 degrees C 32 to 131 degrees F
Storage Temperature	-40 to 65 degrees C -40 to 149 degrees F
Humidity	0 to 90% RH, noncondensing
Dimensions	1/4 DIN front panel (96mm X 96mm) 5.8 inches deep
Weight	3 pounds maximum
Vibration	0.5 to 100 Hz at 0.5g
Agency Approvals	UL and CSA
Warranty	3 years, details on the inside back cover.

Appendix E Software Record/Reference Sheet

Model Number _____

ProgramMode	
InPs	
Icor	
out1	
o1uL	
o1LL	
out2	
o2uL	
o2LL	
out3	
rLyA	
rLyb	
rLyC	
diSP	
dPoS	
Euu	
EuL	
HyCo	
HyAo	
SPC	
rSPu	
rSPL	
SPuL	
SPLL	
AtFr	
PFF	
dFF	
FACn	
Prnd	
Co1r	
Co2r	
Pout	
Pou	
PoL	
P1EC	
P2EC	

ProgramMode Continued	
SPrr	
CCon	
CbS	
CAd	
AduL	
AdLL	
ASuL	
ASLL	
CrC	
CAC	
AAo	
AtL	
ASo	

TuneMode	
PAL	
dAL	
dbAL	
Pb1	
Pb2	
rSt	
ArS1	
ArS2	
rt1	
rt2	
Ct1	
Ct2	
SEnS	
FoP	
SoP	

EnableMode		
ENAB	ON	OFF
EtSt		
ECAL		
EPro		
Etun		
ESby		
ESPS		
ESPC		
EAtn		

Comm

Warranty and Return Statement

These products are sold by the factory under the warranties set forth in the following paragraphs. Such warranties are extended only with respect to a purchase of these products, as new merchandise, directly from the factory or from a factory distributor, representative or reseller, and are extended only to the first buyer thereof who purchases them other than for the purpose of resale.

Warranty

These products are warranted to be free from functional defects in materials and workmanship at the time the products leave the factory and to conform at that time to the specifications set forth in the relevant instruction manual or manuals, sheet or sheets, for such products for a period of three years.

THERE ARE NO EXPRESSED OR IMPLIED WARRANTIES WHICH EXTEND BEYOND THE WARRANTIES HEREIN AND ABOVE SET FORTH. THE FACTORY MAKES NO WARRANTY OF MERCHANTABILITY OR FITNESS FOR A PARTICULAR PURPOSE WITH RESPECT TO THE PRODUCTS.

Limitations

The factory shall not be liable for any incidental damages, consequential damages, special damages, or any other damages, costs or expenses excepting only the cost or expense of repair or replacement as described above.

Products must be installed and maintained in accordance with the instructions. Users are responsible for the suitability of the products to their application. There is no warranty against damage resulting from corrosion, misapplication, improper specifications or other operating condition beyond our control. Claims against carriers for damage in transit must be filed by the buyer.

This warranty is void if the purchaser uses non-factory approved replacement parts and supplies or if the purchaser attempts to repair the product themselves or through a third party without factory authorization.

Returns

The factory's sole and exclusive obligation and buyer's sole and exclusive remedy under the above warranty is limited to repairing or replacing (at factory's option), free of charge, the products which are reported in writing to the factory at its main office indicated below.

The factory is to be advised of return requests during normal business hours and such returns are to include a statement of the observed deficiency. The buyer shall pre-pay shipping charges for products returned and the factory or its representative shall pay for the return of the products to the buyer.

Approved returns should be sent to: 2 CAMPION ROAD
NEW HARTFORD, NY 13413 USA

