

CT-1000 Series

Potentiometric Level Sensors

- ▶ Suitable in all electrically conductive liquids
- ▶ Resolution better than $\pm 0.039''$ (1mm)
- ▶ Micro-controlled measurement analysis
- ▶ 2-wire terminal (4-20mA)
- ▶ Measuring result independent of pressure, temperature and density
- ▶ Filling level or separating layer coverage
- ▶ Very short measuring times
- ▶ Hart protocol version 6.0
- ▶ Temperature range up to 390°F (200°C)
- ▶ Pressure up to 2,175 PSI (150 bar)—at room temperature
- ▶ Lengths from 8' to 19.7' (0.2 to 6 meters)

The high precision and robust level sensor is designed for use in continuous filling level measurement or continuous separating layer coverage. It is suitable for all electrically conductive liquids.

Specifications

Housing	
Protection Type	IP 68
Material	Stainless Steel (Options: Hastelloy®, Tantalum, Titanium) ¹
Cable Diameter	0.2" to 0.4" (5 to 10 mm)
Probe Tube	
Diameter	0.236" (6 mm)
Material	Stainless Steel - 316 TI
Length	8' to 19.7' (0.2m to 6m)
Pressure Range	2175 PSI (150 bar) @ 68°F (20°C) 362 PSI (25 bar) @ 302°F (150°C)
Temperature	
Ambient	-13°F to +176°F (-25°C to +80°C)
Process	Normal Temp: -40° to 257°F (-40° to 125°C) ²
Electrical	
Connection	2-wire
Supply	10 to 30 VDC
Current Signal	4 to 20 mA
Error Message	Adjustable to 3.6 or 21.5 mA
Measuring Accuracy	
Linearity	$\pm 1\%$
Filling Level	Better than $\pm 0.039''$ (1mm)
Resolution	$< 0.004''$ (0.1mm)
Analog Part	$\pm 0.1\%$ (20°C) + 0.005% / °K
Interfaces	
	4-20 mA (2-wire technology) HART Communication Protocol USB

Notes:

1. Please contact Gems for alternate housing materials.
2. High temperature version (to 392°F / 200°C) available. Please contact Gems.

Operating Principle

The sensor works according to the potentiometric measuring principle. By means of the micro-controlled sensor electronics the current impulses are transmitted through the sensor electrode which is electrically insulated from the tank or external tube. This leads to a linear voltage drop on its electrical resistance. If the sensor electrode is dipped into a conductive liquid ($\geq 1 \mu\text{S/cm}$) an electrical connection to the environment is created. The electrical potential is proportional to the filling level and is measured via a counterelectrode or the tank wall. In order for the input resistance of the measuring electronics to be big enough compared to the electrical resistance of the medium the conductivity of the liquids has to be $\geq 1 \mu\text{S/cm}$.

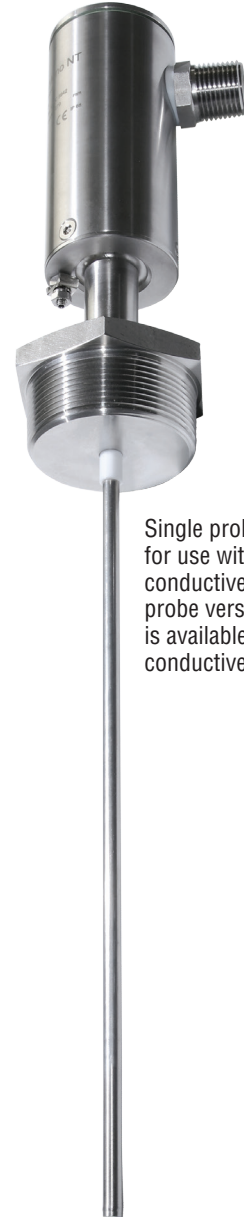

Single probe version for use with electrically-conductive tanks. A dual probe version (not shown) is available for non-conductive tanks.

Mounting Types

Size	Material	Mounting Type	Code
2" NPT	316 Stainless Steel	Threaded	2
3" - 150# ANSI		Flange	3
R 3/4"		Threaded	4
R 1/2"		Threaded	5
R 1"		Threaded	6

How to Order

Use the **bold** characters from the chart below to construct a product code

CT-1000 - 0 - **XXXX** - **X** - **X** - 1 - 0 - **X** - **XXX**

Probe Lengths

Probe Length is 8-236 inches or 200-6000 millimeters, and may be specified in either unit. Label with "in" when using inches, or with "mm" when using millimeters.

Length Ordering Code Examples:

12 inches = **12in**; 125 inches = **125in**
 2830 millimeters = **2830mm**; 350 millimeters = **350mm**

Rod Type

- 0** - 1 Rod
- 1** - 2 Rods (for non-conductive tanks)

Mounting Type

- 2** - 2" NPT Threaded, 316 Stainless Steel
- 3** - 3" 150# Flange, 316 Stainless Steel
- 4** - R 3/4" Threaded, 316 Stainless Steel
- 5** - R 1/2" Threaded, 316 Stainless Steel
- 6** - R 1" Threaded, 316 Stainless Steel

HART

- 0** - None
- 1** - HART Protocol

Options

- 001** - Cable Gland
- 002** - 1/2" NPT Conduit Adapter

Dimensions – in. (mm)

Threaded

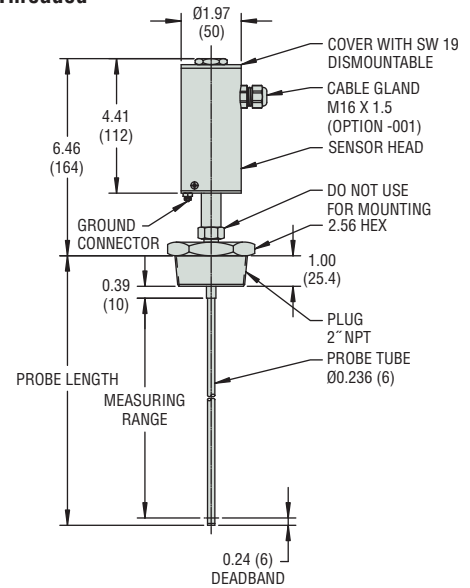

Flange

