

 **All lined up**

Modular ,top hat' rail-mounting system for use in process control applications

rail line



Save time and costs with distributed automation

Decentralized installations with field bus systems are finding increasing use in process and machine automation. In order to ensure reliable control in these allocations – also involving complex processes – modular components with additional functionality are required. With the flexible rail line system, WEST Control Solutions offers a comprehensive product portfolio for decentralized automation.

The combination of RL field bus couplers (for Profibus, CAN, Modbus TCP, and Modbus RTU) with radio module, I/O module RL 400, KS 45 universal controller, Uniflex CI 45 and SG 45 transmitters, and the TB 45 temperature limiter, permits modular systems with distributed intelligence to be created.

Thanks to the space-saving modules for ,top hat' rail mounting, and other universally applicable system components, rail line helps to save time and costs during system configuration, engineering, and commissioning.

The features

- Range of intelligent devices for decentralized automation
- Cost-saving ,top hat' rail mounting technology
- Compact design
- Comprehensive stand-alone functionality
- Field bus coupler for Profibus, CAN, Modbus TCP, Modbus RTU, and Ethernet IP

Controlling, measuring, converting, and monitoring: the rail line product family



COMMUNICATION

Field bus couplers RL DP / RL ETH-IP / RLCAN, and RTU radio module

- RL DP for Profibus DP
- RL Ethernet IP
- Modbus/TCP protocol
- RL CAN for CANopen
- Modbus RTU
- Central power supply



I/O MODULE

RL 400 I/O system

- Signal processing in the modules
- Online correction of measurement value
- Analog plus 16-bit technology
- Up to 32 function modules can be connected
- Digital and analog input & output modules
 - Pt 100 in 2 or 4-wire connection
 - Thermocouples
 - mA/V
 - Relays
 - potential-free digital inputs)
 - NPN/PNP inputs
- Galvanic isolation up to 300 V

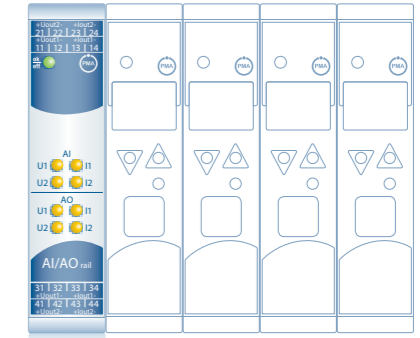

CONTROLLER

KS 45

- Display- and operating functions
- 2-point, 3-point, motor valve, and continuous control
- Fast sampling rate
- Two universal inputs possible
- Universal output
- Timer and programmer
- Customized linearization profile
- Auto/manual switchover
- Direct connection of RS 485 Modbus RTU without bus coupler. Inter-module connections permit additional controllers, transmitters, and limiters to be fitted without wiring.

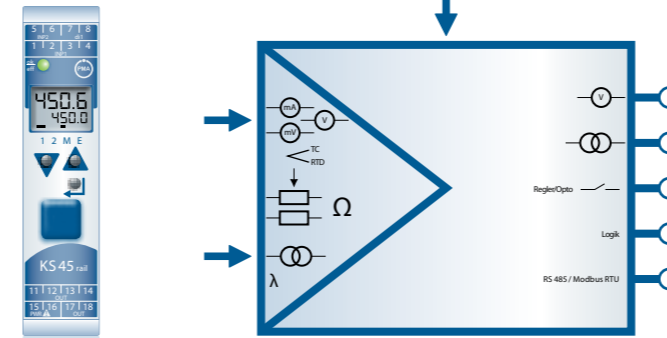

TEMPERATURE LIMITER

TB 45

- For all thermocouple types and resistive sensors
- Display and operating functions
- Two relay outputs
- Analog output
- Two universal inputs possible
- Reset via key combination or external contact
- Direct connection of RS 485 Modbus RTU without bus coupler. Inter-module connections permit additional controllers, transmitters, and limiters to be fitted without wiring.
- Type-tested to EN 14597 (replaces DIN 3440)

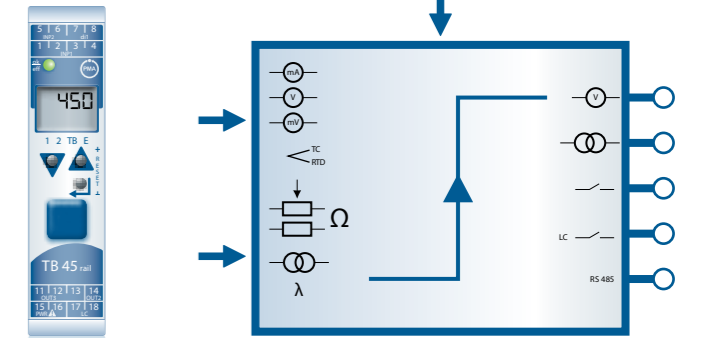

rail line: The system at a glance

<h3>COMMUNICATION</h3> <p>Field bus coupler Simple field bus integration of universal transmitters, universal controllers, and temperature limiters as well as I/O modules in superordinate systems (PLC/SCADA)</p> <p>Radio module Central coupling module for wireless data transmission (HART protocol)</p>	<h3>I/O MODULE</h3> <p>RL 400 I/O system Digital and analog inputs and outputs</p> <ul style="list-style-type: none"> • Pt 100 in 2 or 4-wire connection • Thermocouples • mA/V • Relays • potential-free digital inputs • NPN/PNP inputs 	<h3>CONTROLLER</h3> <p>KS 45 Flexible universal controller with integral self-tuning</p>	<h3>TRANSMITTERS</h3> <p>UNIFLEX CI 45 Programmable universal transmitter with display</p> <p>UNIFLEX SG 45 Special-purpose transmitter for strain gauge input (e.g. load cells and melt pressure sensors)</p>
		<h3>TEMPERATURE LIMITER</h3> <p>TB 45 Reliable temperature limiter, monitor, and limit signaller</p>	

TRANSMITTER

CI 45

- High resolution
- Fast sampling rate
- Two universal inputs possible
- Universal output
- Two relay outputs
- Counter/frequency input, frequency output
- Customized linearization profile
- Correction of measurement value
- Slave pointer (min/max indicator)
- Direct connection of RS 485 Modbus RTU without bus coupler. Inter-module connections permit additional controllers, transmitters, and limiters to be fitted without wiring.

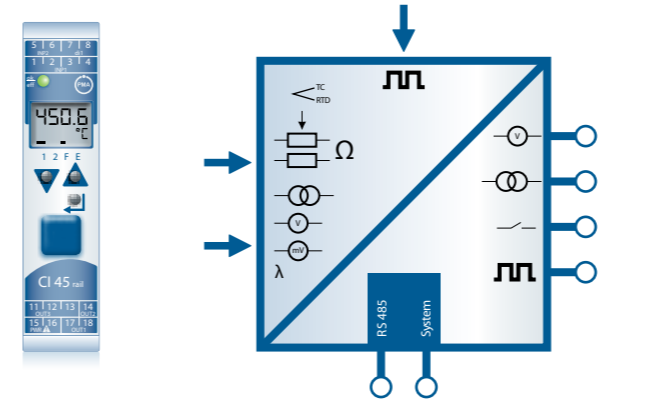

SG 45

- Special-purpose transmitter for strain gauge input
- 24-bit universal input
- Voltage supply for the strain gauge bridge
- Simple scaling during commissioning
- 4 or 6-wire connection for force measurement
- 2 relay outputs
- Direct connection of RS 485 Modbus RTU without bus coupler. Inter-module connections permit additional controllers, transmitters, and limiters to be fitted without wiring.

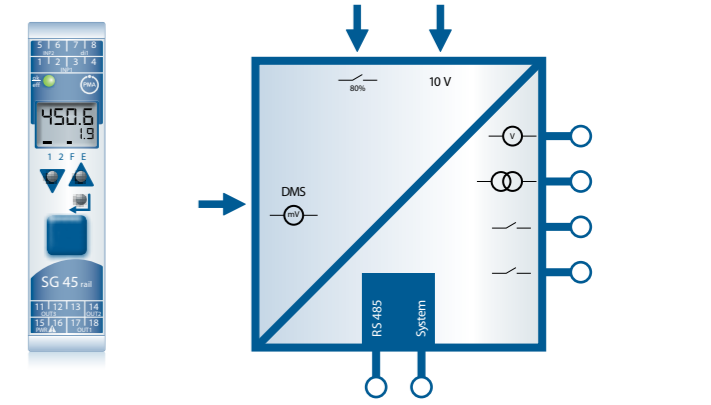

Compact, multi-functional and flexible

System features



- Inter-module connections without wiring
- Space-saving rail mounting
- Communication via field bus coupler
- Hot swap facility



- Plug-in screw terminals or spring-clamp connectors

MODULE FEATURES

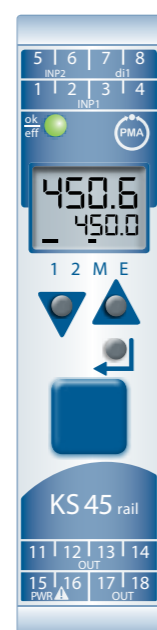
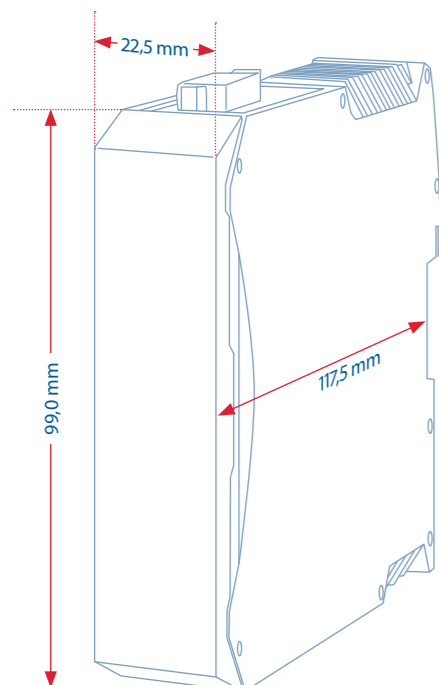

Technical details

- Field bus coupler for Profibus, CAN, Modbus TCP, Modbus RTU, and Ethernet IP – ensures cost-effective and convenient connections to PLC, IPC, and operating terminals
- Bus monitoring
- Pre-defined output states in case of communication failure
- Compact design – modules only 22,5 mm wide
- 3-key operation, and multi-line LC display
- Plug-in terminals – no wiring to disconnect in case of module replacement
- Module replacement during operation (hot swap)
- BluePort® front port
- PC configuration tool BlueControl®
- Cost advantages during projecting, implementation, and maintenance
- Local operation
- Freely configurable menu structure
- Freely selectable monitoring functions

BlueControl®: The Engineering Tool

On-site commissioning, and remote configuration



- Powerful tool for setting parameters, simulation, commissioning, and diagnosing
- Fast configuration and commissioning of the system via the BluePort® front interface on the field bus coupler
- Reliable copying of device parameters
- Settings are tested with the built-in device and process simulation
- Archiving and documentation

Configuration



Device simulation



Trend recording



WEST Control Solutions your global partner for temperature and process control



Austria
PMA Prozeß- und Maschinen-Automation GmbH
Liebermannstraße F01 · A-2345 Brunn am Gebirge
Tel: +43 (0)2236 691-121 · Fax: +43 (0)2236 691-102
info@pma-online.at

Germany
PMA Prozeß- und Maschinen-Automation GmbH
Miramstraße 87 · D-34123 Kassel
Tel: +49 (0)561 505-1307 · Fax: +49 (0)561 505-1710
mailbox@pma-online.de

Brochures and datasheets are available for the complete range of West Control Solutions products, contact your local sales office for more information or visit our website at: www.west-cs.com

China
Danaher Setra-ICG
Tianjin Co. · Ltd. No.28 Wei 5 Road
The Micro-Electronic Industry Park TEDA
Xiqing District · Tianjin 300385
Tel: +86 22 8398 8098 · Fax: +86 22 8398 8099
Sales Hotline: 400 666 1802
tc.sales@danaher.com

United Kingdom
West Control Solutions
The Hyde Business Park
Brighton · East Sussex · BN2 4JU
Tel: +44 (0)1273 606271 · Fax: +44 (0)1273 609990
info@westinstruments.com

France
Hengstler Controle Numerique · 383 Rue de la Belle Etoile
Bat T3 · Allée du Ponant · 95940 Roissy en France
Tel: +33 (1) 77 80 90 40 · Fax: +33 (1) 77 80 90 50
info@westinstruments.com

USA
West Control Solutions
1675 Delany Road · Gurnee · IL 60031-1282
Tel: 800 866 6659 · Fax: 847 782 5223
custserv.west@dancon.com

